



AUSPEX

Field Service Guide Supplement for the NS 7000/030

Copyright© 1998, Auspex Systems, Inc. All rights reserved. Part number 850550.

Important Notice

The installation or replacement procedures in this document are for trained Auspex service personnel only. There are no user-serviceable Field Replaceable Units (FRUs) inside the Auspex product.

Contents

Introduction	1
HDDA Chassis and Drive Drawers.....	3
Replacing an HDDA Chassis	3
Replacing a Drive Drawer	9
Adding a Drive Drawer	17
Replacing a Drive Drawer Fuse	18
Power System	24
HDDA Bulk Power Supplies.....	24
Power Distribution Unit (PDU)	28
Power Shelf Chassis.....	31
Disk DC Converter (DCC)	35
Maintenance.....	43
Checking and Replacing a Fan.....	43
Replacing SCSI Cables.....	45
HDDA Monitoring Board	47
Installing an HDDA Monitoring Board	47
HDDA Monitoring Board Messages	50
Field Service Information.....	57
Tools Needed for Replacement Procedures.....	57
FRU Part Numbers.....	57

Figures

Figure 1.	NS 7000/030 storage subsystem (front view)	10
Figure 2.	NS 7000/030 storage subsystem (back view)	10
Figure 3.	Rear cover plate and power cable cutout	12
Figure 4.	Removing the plastic snap-catch	13
Figure 5.	Removing the plastic side covers	14
Figure 6.	HDDA chassis screw locations (side view).....	14
Figure 7.	Drive drawer LEDs (drive drawer front panel)	15
Figure 8.	Bulk power supply LEDs.....	16
Figure 9.	Sample drive drawer configuration (top view).....	17
Figure 10.	NS 7000/030 drive and drawer numbering.....	18
Figure 11.	Unlocking the HDDA drive drawer	19
Figure 12.	Drive drawer front panel.....	20
Figure 13.	Removing an HDDA drive drawer	20
Figure 14.	Unlatching the Disk DCC	21
Figure 15.	Removing and Replacing the Disk DCC	22
Figure 16.	Installing a drive drawer	23
Figure 17.	Cam lever engaging in cam slot.....	23
Figure 18.	Closing a drive drawer.....	24
Figure 19.	Locking the HDDA drive drawer.....	24
Figure 20.	HDDA LEDs (drive drawer front panel).....	27
Figure 21.	Drawer fuses and LEDs location (HDDA back view)	27
Figure 22.	Unlocking the HDDA drive drawer	29
Figure 23.	Opening the drive drawer	29
Figure 24.	Location of Power Supplies.....	32
Figure 25.	Bulk power supply LEDs.....	33
Figure 26.	NS 7000/030 power system (back view)	37
Figure 27.	PDU mounting screw locations	37
Figure 28.	Bulk power supply chassis (back)	40
Figure 29.	Removing the plastic snap-catch	40
Figure 30.	Removing the plastic side covers	41
Figure 31.	Power shelf chassis screw locations (side view)	41
Figure 32.	Disk DCC LED (drive drawer front panel)	43
Figure 33.	Unlocking the HDDA drive drawer	44
Figure 34.	Opening the drive drawer	45
Figure 35.	Unlatching the Disk DCC	46
Figure 36.	Removing the Disk DCC.....	46
Figure 37.	Inserting the Disk DCC	47
Figure 38.	Closing the HDDA drive drawer	48
Figure 39.	Cam lever engaging in cam slot.....	48
Figure 40.	Latching the HDDA drive drawer	49
Figure 41.	Locking the HDDA drive drawer.....	49
Figure 42.	Location of fan LED.....	51
Figure 43.	Location of HDDA fans (back of HDDA chassis)	52

Figure 44. Example SCSI cabling for NS 7000/030 (back view) 54
Figure 45. HDDA monitoring board location 55
Figure 46. Installing the HDDA monitoring board 56
Figure 47. HDDA fan numbers 58

Tables

Table 1.	Bulk power supply LED status	25
Table 2.	Disk DCC LED status	35
Table 3.	HDDA monitoring board specification list	51
Table 4.	HDDA drawer error codes	52
Table 5.	HDDA drawer error descriptions	53
Table 6.	Monitoring board error codes	55
Table 7.	Monitoring board error descriptions	56
Table 8.	HDDA installation and replacement tools	57
Table 9.	FRU part numbers	58

Introduction

The NS 7000/030 is a modular storage subsystem that provides additional disk storage for the NS 7000 Model 150/250 NetServer. This document provides information and procedures for installing or replacing components of the NS 7000/030 storage subsystem.



Note: For information on the NS 7000 Model 150/250 NetServer, refer to the *NS 7000 Model 150/250 Series Hardware Manual*.



Caution: This guide contains the information that a qualified Auspex service representative needs to service the HDDA components on a NetServer. Customers should not attempt the procedures in this guide unless they complete the appropriate Auspex training class.

The NS 7000/030 storage subsystem contains the following subassemblies:

- ▲ High Density Disk Assembly (HDDA) (2)
- ▲ PDU shelves (1-2)

This document contains information on and procedures for the following:

- ▲ HDDA chassis and drive drawers
- ▲ Power systems for the HDDA
- ▲ HDDA fan and SCSI cables
- ▲ HDDA monitoring board
- ▲ FRU part numbers

For all other information about the NS 7000/030 storage subsystem, please refer to the *NS 7000/030 Storage Subsystem Hardware Manual* (part number 850540).

Figure 1 and Figure 2 show the front and back views of the NS 7000/030 storage subsystem, respectively.

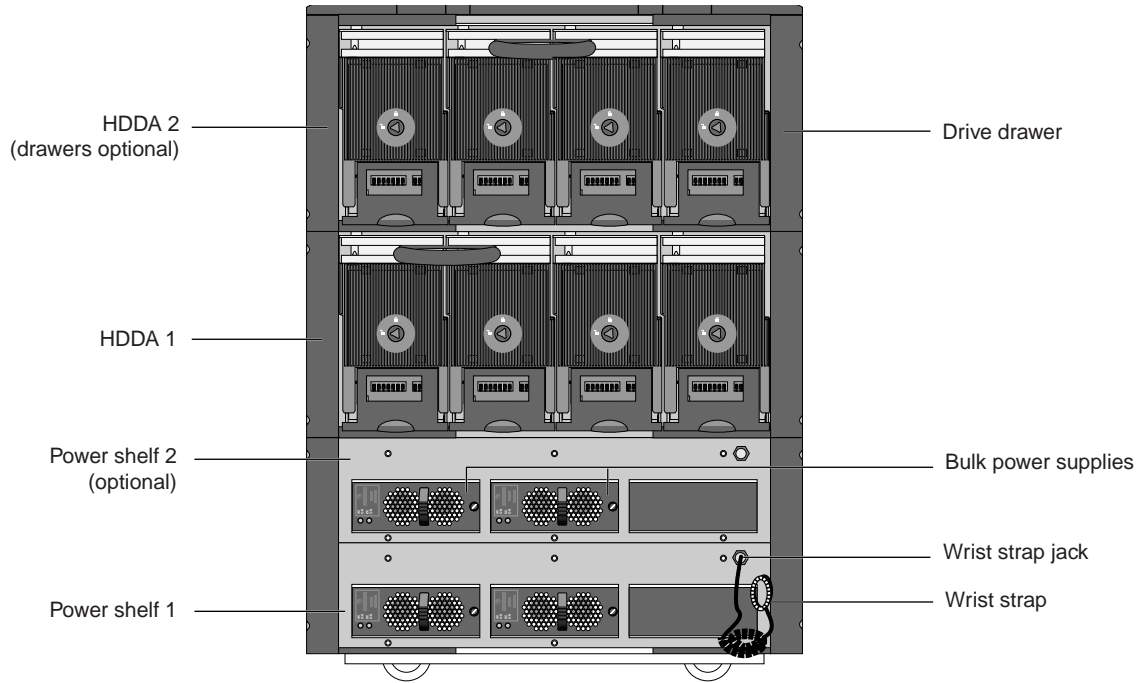

Figure 1. NS 7000/030 storage subsystem (front view)

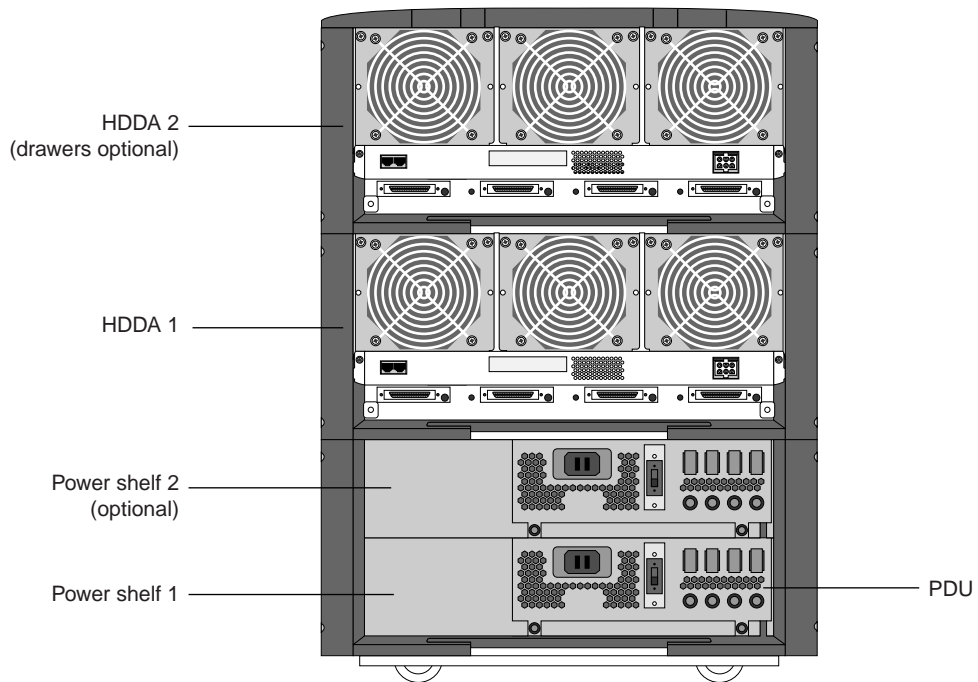

Figure 2. NS 7000/030 storage subsystem (back view)

HDDA Chassis and Drive Drawers

The HDDA has four components:

- ▲ HDDA chassis, which houses the drive drawers
- ▲ Drive drawers, which house the disk drives
- ▲ Disk drives, up to seven in each drive drawer
- ▲ Disk DC Converter (DCC), one in each drive drawer

The NS 7000/030 contains two HDDA chassis. The bottom chassis is HDDA 1, and the top chassis is HDDA 2. Figure 1 on page 2 shows the location of each HDDA chassis.

The drive drawers that house the HDDA drives are numbered 1 to 4, from left to right in each HDDA chassis. Figure 10 on page 10 shows the drive drawers and the naming conventions for the drives in each drawer.

This section contains procedures for replacing the HDDA chassis, drive drawer, and drive drawer fuse.

Replacing an HDDA Chassis

The HDDA chassis assembly supports up to four drawer assemblies. Blank panels cover unused drawer slots.

The HDDA replacement chassis assembly contains the HDDA chassis, with the cover plate attached to the back.



Caution: An empty HDDA chassis weighs 35 lbs. and needs to be handled carefully to avoid damage. Auspex recommends using two people to slide the HDDA out of and into the chassis to avoid personal injury and damage to the equipment.



Note: Each HDDA chassis is mounted independently from the other chassis; therefore, you do not need to remove both to replace a failed chassis. If, however, you are replacing the chassis for HDDA 1, you can remove the HDDA 2 chassis first for easier access and handling, but it is not necessary.



Tools

- ▲ Antistatic wrist strap
- ▲ #1 Phillips screwdriver
- ▲ #2 Phillips screwdriver
- ▲ #2 Flat-blade screwdriver
- ▲ #3/32 Allen driver

To remove an HDDA chassis

1. Attach an antistatic wrist strap to yourself and to the wrist-strap jack located on the front of the power shelf.

2. If the NetServer is running, enter the following command at the root prompt to halt the NetServer's operation:

```
# shutdown -1h +5 "message"
```

where **1** sends the warning message to users who are logged in, **h** halts the HP and causes the server to enter monitor mode, **+5** is the time in minutes before the NetServer operating system comes to a halt, and *message* informs connected clients about the shutdown.

3. Once the monitor prompt (HP>) appears on the screen, turn off the main power switch on the storage subsystem, and then turn off the main power switch on the base cabinet.
4. Remove the SCSI cables from the chassis you are replacing.
 - ▲ If the SCSI cables are not labeled, label them now for proper reattachment.
 - ▲ If you have caps to cover the SCSI connector pins, attach the caps now to prevent damage to the pins.
5. Remove the drawer assemblies in the affected HDDA chassis by following step 2 through step 12 in "To remove a drive drawer" beginning on page 10 of this guide. Carefully set the drawers on an antistatic mat.

 **Caution:** When handling the drive drawers, use care to avoid any jarring or sudden jolts to the drawer. Set the drawer gently on a flat, antistatic surface. A sudden, jarring movement can damage the disk drives.

6. Remove the drive drawer slot covers for the empty drawer slots (if any) and save them for the new installation.
 - a. Remove the plastic bezel on the front of the HDDA drawer slot cover.
 - b. Use a 3/32 Allen wrench to remove the screw at the bottom of the slot cover.
 - c. Remove the drive drawer slot cover and set it aside with the screw for later use.
7. Remove the antistatic wrist strap once you are finished removing the drive drawer assemblies.
8. Use a #1 Phillips screwdriver to release the rear cover plate on the HDDA chassis (Figure 3).

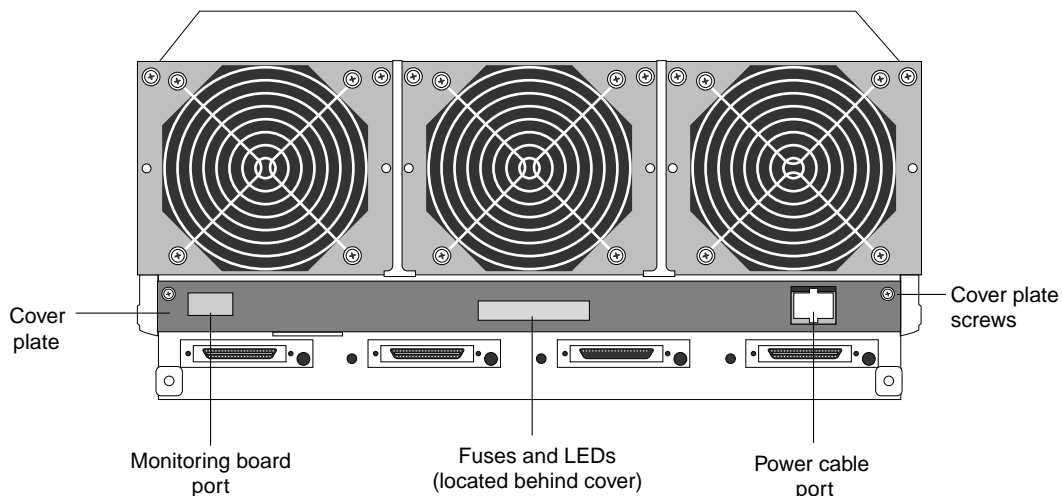

Figure 3. Rear cover plate and power cable cutout

9. Use two flat-blade screwdrivers to squeeze the release tabs at the top and bottom of the power cable connector to disconnect it, and then thread it out through the cut-out in the cover plate.



Note: Flat-blade screwdrivers are needed to release the tabs due to the limited space between the tab and chassis.

10. Remove the HDDA monitoring board from the back of the failed chassis.
 - a. Remove the RJ45 connector from the monitoring board (if attached). Thread the cable out through the cut-out in the cover plate.
 - b. Using your fingers, gently pull the monitoring board out of the port.
 - c. Set the monitoring board aside for installation into the new chassis.

Refer to the “HDDA Monitoring Board” section starting on page 47 of this document for more information and illustrations on the monitoring board.

11. Reattach the cover plate to the back of the failed chassis.
12. Remove the plastic side covers surrounding the HDDA and the top cover of the NS 7000/030.
 - a. Use a small flat-blade screwdriver to pop off the teal snap-catches that hold the plastic covers to the unit (Figure 4). There are a total of eight snap-catches for each HDDA chassis.

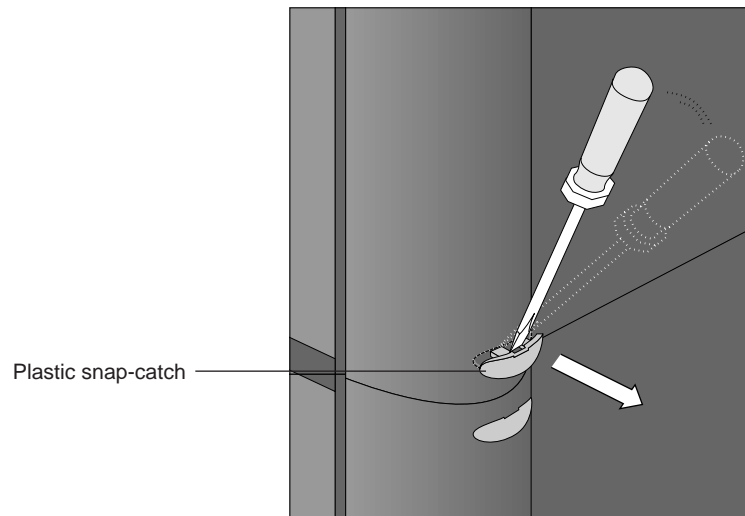

Figure 4. Removing the plastic snap-catch



Note: The top cover is held into place by the four snap-catches on each corner at the top of the NS 7000/030. You must remove these snap-catches before removing or installing the top cover.

- b. Remove the top cover by gently lifting it off the unit.
- c. Using one hand, lift the plastic cover from the curved edge and, using your other hand to hold the bottom edge of the cover, gently pry it off (Figure 5).

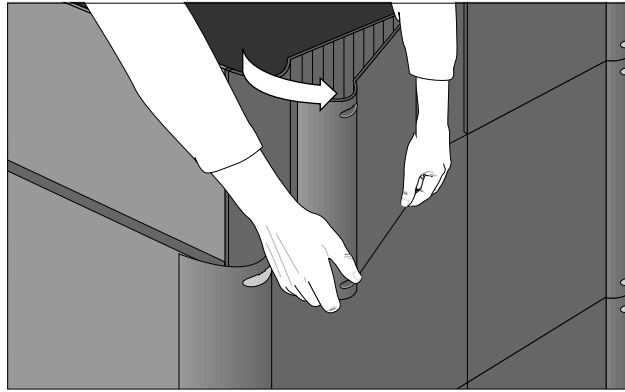

Figure 5. Removing the plastic side covers

- d. Repeat step c until you have removed all four covers. For each HDDA chassis, there are four plastic covers--two on the left side and two on the right.
13. Using a #2 Phillips screwdriver, remove the eight screws (four on each side) that secure the HDDA chassis to the frame. See Figure 6 for screw locations.

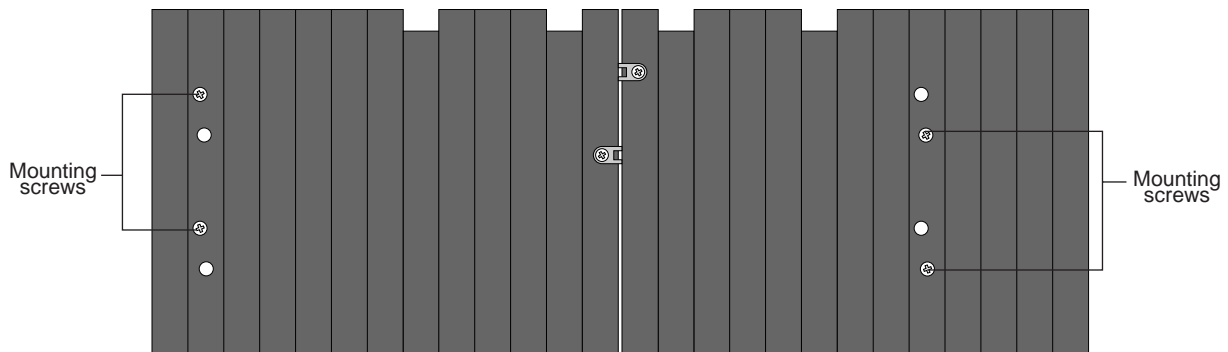

Figure 6. HDDA chassis screw locations (side view)



Caution: The HDDA chassis weighs 35 lbs. Use two people to remove the HDDA chassis from the unit to avoid injury.

14. From the back of the unit, push the HDDA chassis forward to slide it out of the system.
If you are removing HDDA 2, you can also lift it up and out of the system.



Caution: Do not slide the HDDA chassis out by pulling it from the front of the system. Doing so can damage the metal drawer separators.

To replace an HDDA chassis

1. Slide the replacement HDDA chassis into the NS 7000/030 frame and align the screw holes in the side of the chassis with the screw holes in the side of the frame (Figure 6). Make sure the front of the HDDA is flush with the front edge of the plastic frame.
2. Replace the eight screws that you removed in step 13 of the previous procedure to secure the chassis to the frame.
3. Install the plastic side covers, aligning the tabs on each side cover, and snap them into place.
4. Align the top cover with the corners of the plastic side covers and snap it into place.
5. Install the eight teal snap-catches by pushing them into their slots. You will hear a click when the snap-catch is installed correctly.
6. Use a #1 Phillips screwdriver to remove the rear cover plate from the replacement chassis.
7. Install the HDDA monitoring board using the procedure, “Installing an HDDA Monitoring Board” on page 47 of this document.
8. While holding the cover plate in one hand, thread the power cable through the cut-out in the rear cover plate, and connect the power cable to the back of the chassis (Figure 3 on page 4).
9. Reattach the cover plate to the back of the chassis. (See Figure 3 for screw locations.)
10. Reattach the antistatic wrist strap.
11. Install the drive drawer assemblies into the chassis by following step 4 through step 10 in “To replace a drive drawer” beginning on page 14.

Make sure you reinstall drawer slot panels into any vacant drive drawer slots.

12. Affix the appropriate drive drawer labels to the front of each HDDA drive drawer.
13. Connect the SCSI cables to the appropriate location on the chassis.
14. Apply power to the NS 7000/030 storage subsystem, then the base cabinet.
15. Check the LEDs on the front of the drive drawers, as well as the bulk power supply LED status indicators, to verify operation (Figure 7 and Figure 8).
16. Place the empty chassis and unneeded hardware into the shipping carton for shipment to Auspex.

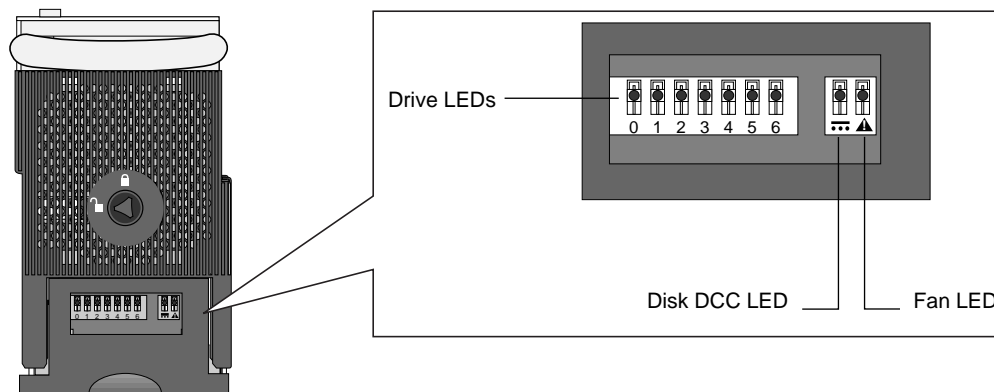

Figure 7. Drive drawer LEDs (drive drawer front panel)

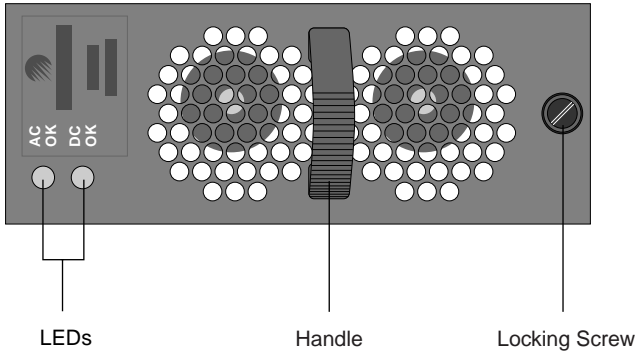

Figure 8. Bulk power supply LEDs

This concludes the procedure for replacing an HDDA chassis.

Replacing a Drive Drawer

Each HDDA chassis contains up to four drive drawers. The HDDA drive drawers are numbered 1 to 4 from left to right in each HDDA chassis.

Each HDDA drive drawer supports up to 7 disk drives. In each drawer, the drives are numbered right to left, from front to back, as shown in Figure 9.

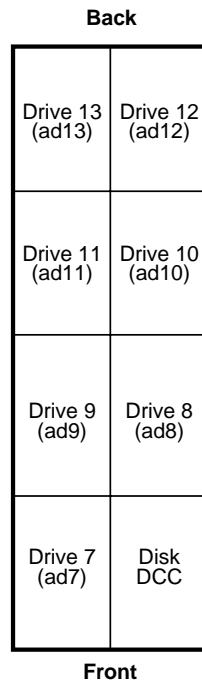

Figure 9. Sample drive drawer configuration (top view)



Note: The drive drawers support disk drives only. They do not support CD-ROM or tape drives.

Figure 10 shows the drive and drawer numbering in the NS 7000/030 storage subsystem. Refer to the *NS 7000 Model 150/250 Series Hardware Manual* for drive and drive drawer numbering in the base cabinet.

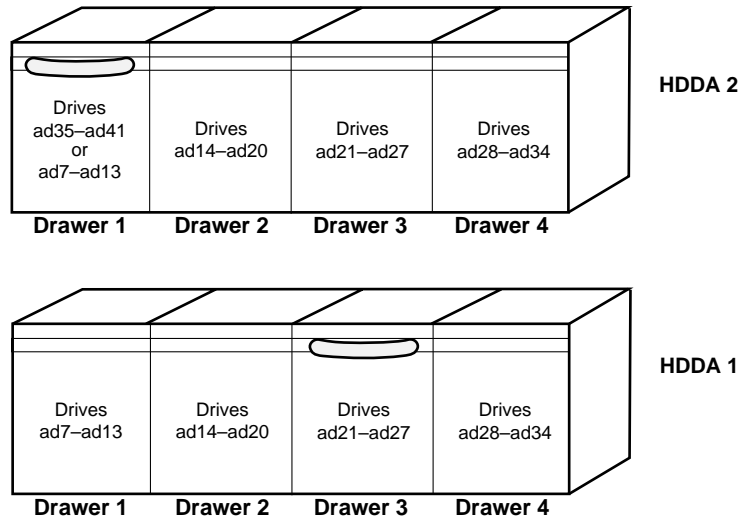

Figure 10. NS 7000/030 drive and drawer numbering

Each drive drawer in the HDDA chassis is “hot-pluggable,” meaning you do not need to power down the entire NetServer to replace drive drawers. You do, however, need to spin down the drives in the selected drive drawer prior to replacement.

This section describes how to replace an HDDA drive drawer in the NS 7000/030 storage subsystem.



Tools

- ▲ Antistatic wrist strap
- ▲ Antistatic mat
- ▲ 3/32 Allen wrench
- ▲ Drive drawer key

To remove a drive drawer

1. Put on the antistatic wrist strap, and wear it throughout the procedure.
2. Locate the HDDA drive drawer key and unlock the drive drawer (Figure 11).

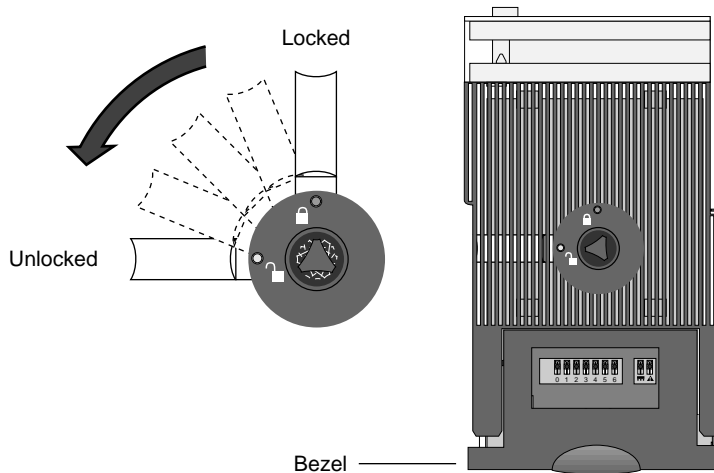

Figure 11. Unlocking the HDDA drive drawer

3. Slide the drawer handle to the selected drive drawer, but do **not** open the drawer yet.
If the NetServer is powered off, skip to step 7.
4. Gain access to the NetServer on the system console.
5. Enter the **ax_hot_plug** command to spin down each of the drives in the drive drawer you are replacing.

For example, to spin down the drives in drawer 3 of HDDA 1 (slots ad21 to ad27), enter the following command:

```
# ax_hot_plug remove 21-27
```

The system responds:

```
removing device 21.  
All activity on SP0 has been stopped.  
Remove the device.  
Press the <Return> key when you are finished:
```

6. Press the Return key for every drive in the drawer, but do not remove any drives.
7. Remove the lower bezel from the front of the HDDA drawer by lifting it off from the bottom (Figure 11).
8. Using a 3/32-inch Allen wrench, remove the mounting screw from the lower hole position and place it into the upper hole position on the drive drawer bottom panel (Figure 12).



Note: Moving the Allen screw from the lower mounting hole to the upper mounting hole is required to secure the drive drawer to the lower pan before decoupling the drawer from the chassis assembly.

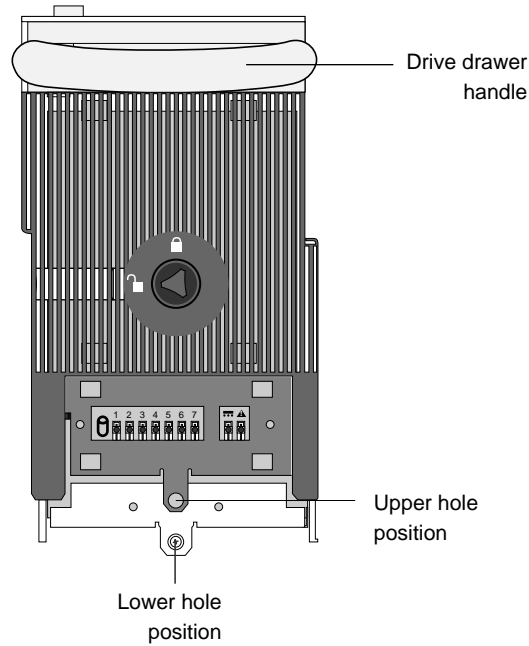

Figure 12. Drive drawer front panel

9. Pull the handle down and slide the drawer out part way, as shown in Figure 13.

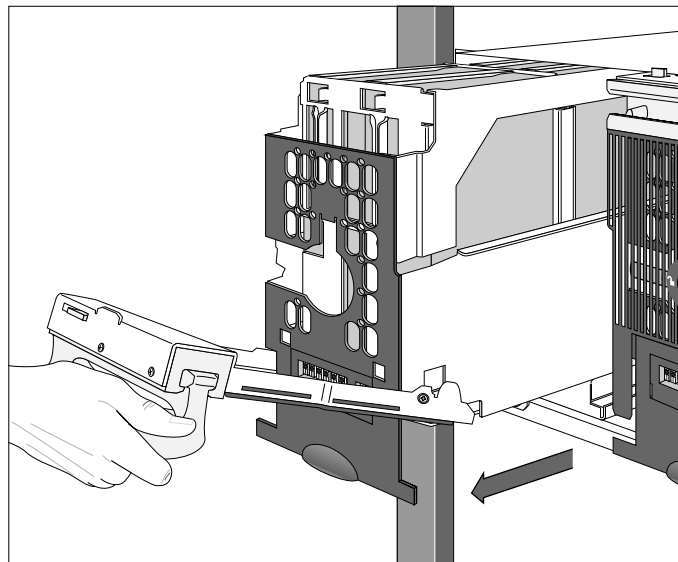

Figure 13. Removing an HDDA drive drawer

10. Continue to pull the drawer out, and if necessary, use your fingers to pull the white plastic support slides slightly away from the drawer to release the drawer from the slides.
11. Holding the drive drawer handle, and cradling the drive drawer with your other hand, carefully remove the drive drawer from the drawer slot.



Caution: When handling the drive drawers, use care to avoid any jarring or sudden jolts to the drawer. Set the drawer gently on a flat, antistatic surface. Sudden, jarring movement can damage the disk drives.

12. Set the failed drawer assembly next to the replacement drawer on an antistatic mat.

To replace a drive drawer

1. Transfer the Disk DCC power module (located in the first slot on the right-hand side of the old drawer) to the replacement drawer assembly:
 - a. Release the retaining clip that secures the Disk DCC handle (Figure 14).
 - b. Grasp the handle and lift the Disk DCC up and out of the drive slot (Figure 15). Use your other hand to support the Disk DCC if necessary, but be careful not to touch the PCB components.

It is normal for the Disk DCC to feel tight when removing it from the drive drawer.

- c. Slide the Disk DCC into the Disk DCC slot in the replacement drawer (Figure 15).
- d. Seat the Disk DCC into position by firmly but gently pressing down on the handle.
- e. Secure the handle using the retaining clip provided on the drive drawer. Neither the Disk DCC nor the retaining clip should protrude above the top of the drive drawer.



Note: The Disk DCC installs in only one direction. If the Disk DCC does not slide in easily, remove the Disk DCC and try again.

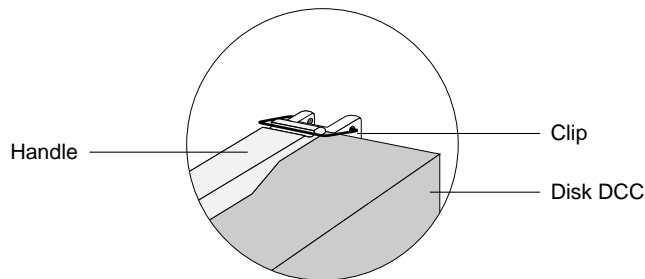

Figure 14. Unlatching the Disk DCC

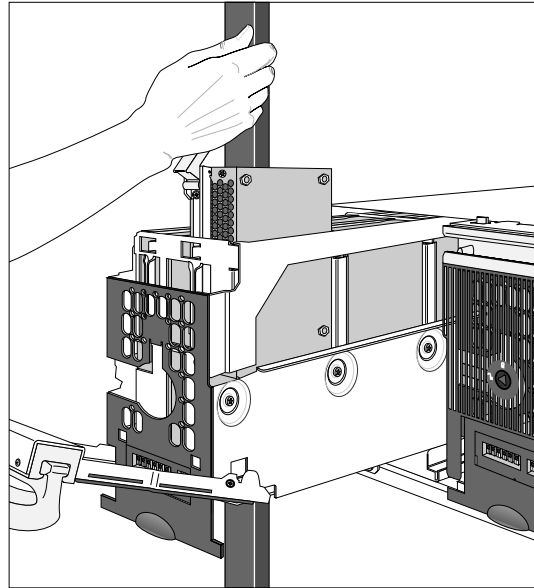

Figure 15. Removing and Replacing the Disk DCC

2. Transfer the drives, one at a time, to their corresponding position in the replacement drawer assembly using the same procedure as for the Disk DCC in step 1.
3. Attach the appropriate drawer label to the front of the replacement drawer.
4. Holding the replacement drive drawer with both hands, align the drive drawer with the side rails in the HDDA chassis, and gently slide the drive drawer halfway into the drawer slot.



Note: Make sure that the drive drawer handle is attached before installing the drawer into the slot. If not, insert the handle into the groove at the top of the drive drawer as shown in Figure 12 on page 12.

5. While holding the handle down, slide the drawer the rest of the way into the slot until it is about 3/4-inch from the HDDA chassis (Figure 16).



Note: Be sure that the drawer faceplate is pulled down far enough to allow the cam lever at the bottom of the faceplate to clear the chassis. Once in position, the lever provides the cam action that firmly seats the drawer into the chassis once it is closed.



Caution: Do not force the drive drawers into the slots; doing so can damage the unit.

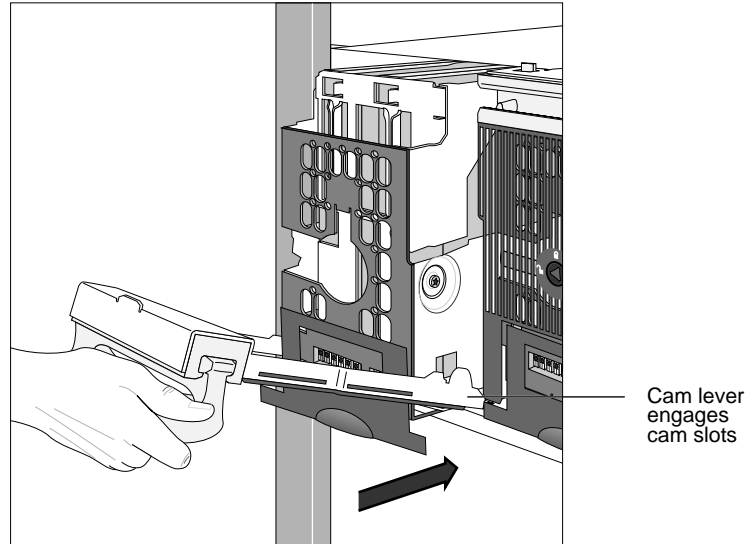

Figure 16. Installing a drive drawer

6. Push the drawer handle up so that the cam lever engages the cam slots in the HDDA chassis, as shown in Figure 17.

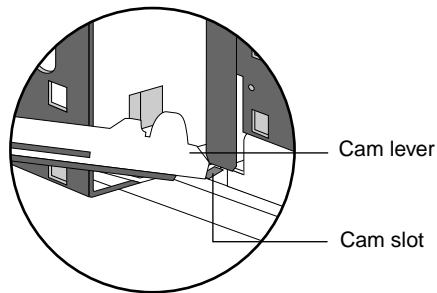

Figure 17. Cam lever engaging in cam slot

7. Once the cam lever is engaged in the slots, seat the drive drawer firmly by pressing the handle closed. The cam action of closing the handle seats the drive drawer properly (Figure 18).
The drawer latch at the top left corner of the drive drawer clicks into position when the drawer is properly seated.

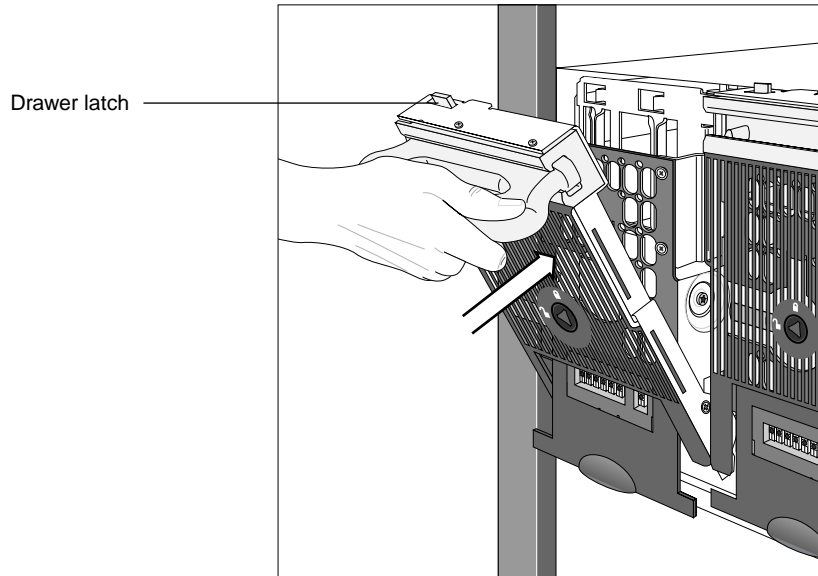

Figure 18. Closing a drive drawer

8. Secure the drive drawer to the HDDA chassis by moving the drawer panel screw from the upper hole position to the lower hole position on the drive drawer front panel (see Figure 12 on page 12 for the hole position).
9. Replace the bezel on the front of the drive drawer.
10. Insert the HDDA drive drawer key and lock the drawer by turning the key clockwise (Figure 19).

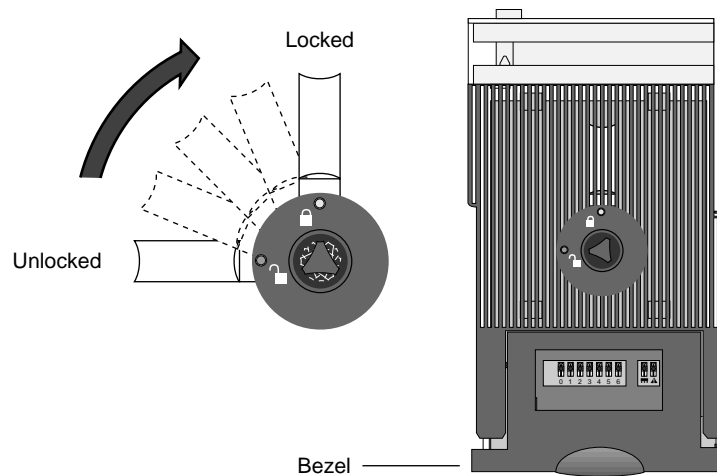

Figure 19. Locking the HDDA drive drawer

11. Restart SCSI activity by entering the **ax_hot_plug** command specifying all of the drives in the replacement drawer.

For example, to add the drives in drawer 3 of HDDA 1 (slots ad21 to ad27), enter the following command:

```
# ax_hot_plug add 21-27
```

The system responds:

```
adding device 21.  
All activity on SP0 has been stopped.  
Insert or replace the device.  
**WARNING** Make sure you insert the drive in the proper slot.  
Otherwise, you may crash the system.  
Press the <Return> key when you are finished:
```

12. Press the Return key for the first drive in the drawer. Repeat this procedure for every drive in the drawer.

This completes the procedure for replacing an HDDA drive drawer.

Adding a Drive Drawer

This section describes how to add an HDDA drive drawer in the NS 7000/030 storage subsystem. Each drive drawer in the HDDA chassis is “hot-pluggable.” Because you are adding a new drawer to an inactive (unused) SP channel, you do not need to suspend I/O activity or power down the NetServer to add drive drawers.



Tools

- ▲ Antistatic wrist strap
- ▲ 3/32 Allen wrench

To add a drive drawer

1. Put on the antistatic wrist strap, and wear it throughout the procedure.
2. Using a 3/32 Allen wrench, remove the slot cover from the slot where you will be installing the drive drawer.
3. Add the new drive drawer assembly into the chassis by following step 3 through step 10 in “To replace a drive drawer” beginning on page 14.



Note: Be sure to note how many drives are included in the new drive drawer. You will need this information in step 6.

4. Once the drawer is installed and locked into position, connect the SCSI cable to the appropriate SCSI port on the back of the HDDA chassis and connect the other end to the appropriate port on the SP.

Figure 44 on page 46 shows SCSI cabling.

5. After the SCSI cable is attached, gain access to the NetServer on the system console.
6. Enter the **ax_hot_plug** command with the **add** option, specifying each drive in the new drive drawer (Figure 9 and Figure 10 show drive numbering conventions). For example:
 - ▲ If you are adding drawer 2 in HDDA 1 and it has one drive in slot 14 (ad14), enter:

```
# ax_hot_plug add 14
```

- ▲ If you are adding drawer 2 in HDDA 1 and it has multiple drives, for example drives in slots 14 through 16, enter:

```
# ax_hot_plug add 14-16
```

In either case, the system responds with messages similar to the following:

```
adding device 14.
All activity on SP0 has been stopped.
Insert or replace the device.
**WARNING** Make sure you insert the drive in the proper slot.
           Otherwise, you may crash the system.
Press the <RETURN> key when you are finished:
```

7. Press the Return key for each drive.

For each drive, the system responds that the drive is added. For example:

```
ad14: <Auspex 9GB cyl 8668 alt 1 hd 16 sec 128>
added device 14.
```

8. Continue to press the Return key until all drives in the new drawer are added.
9. Follow the procedures outlined in the *System Manager's Guide* to partition the new drive, initialize it, and mount file systems on it.
10. Run **ax_config**, and update the server's configuration information.

This concludes the procedure for adding an HDDA drive drawer.

Replacing a Drive Drawer Fuse

Each HDDA has four fuses that correspond with each drive drawer. The fuses protect the 48-volt supply in each drive drawer. In the event of a Disk DCC fault, a wiring or a board fault, the fuse will open.

The drive drawer fuses are located on the back of the HDDA. Each fuse has a corresponding LED next to it that lights when a fuse blows.

If a fuse is blown, the following will occur:

- ▲ No LEDs will be lit on the front of the affected drawer
- ▲ All drives in the affected drawer will be down or "missing" when queried
- ▲ The fuse LED on the back of the HDDA will be lit



Note: A blown fuse may indicate that a Disk DCC is not operating properly. Refer to "Replacing a Disk DCC" on page 36 for procedures on how to replace a Disk DCC.



Caution: Although the drives in the affected drawer will not be operating if a fuse is blown, you must suspend drive activity to prevent rapid spin-up of the drives once the fuse is replaced. In addition, the Disk DCC must be temporarily removed to prevent the replacement fuse from immediately blowing when it is plugged in.

To identify a blown fuse

1. View the front panel LEDs (Figure 20) on each HDDA drive drawer. If all LEDs are off on a drive drawer, it may indicate a blown fuse.

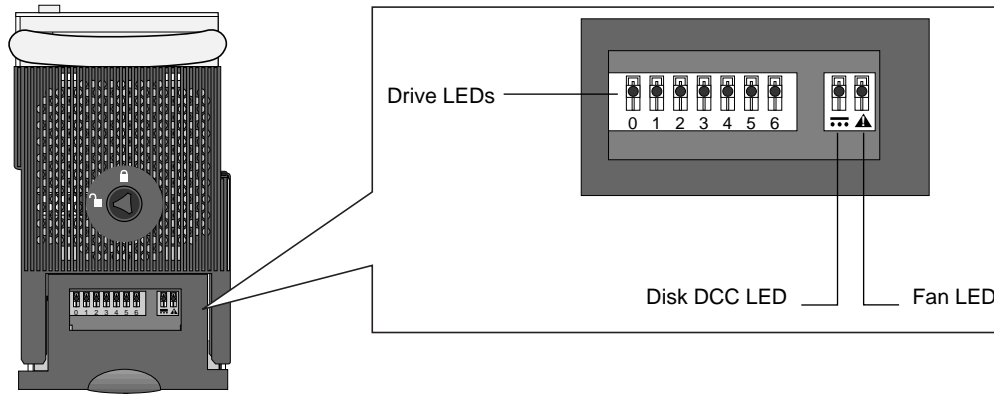

Figure 20. HDDA LEDs (drive drawer front panel)

2. Move to the back of the storage subsystem and remove the screws securing the rear cover plate. Check the fuse LEDs on the back of the drawer (Figure 21).

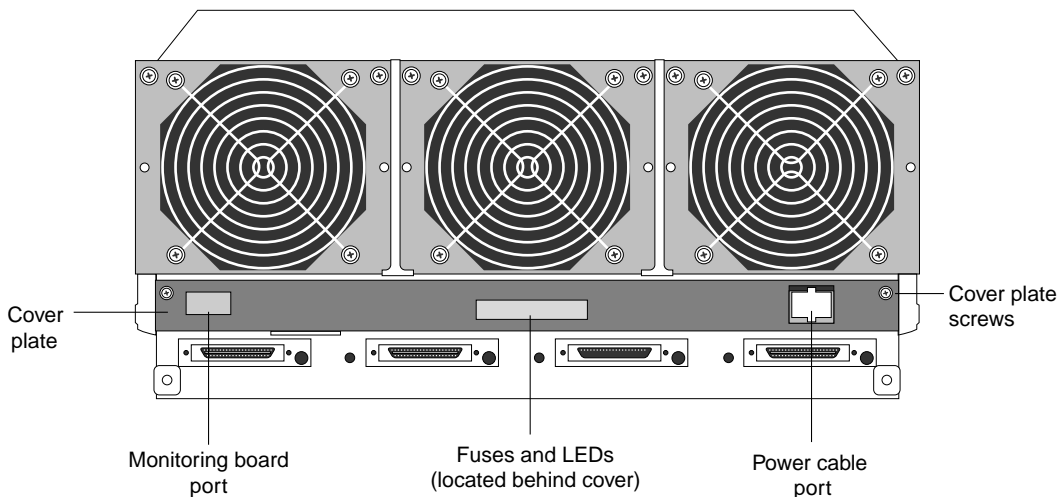

Figure 21. Drawer fuses and LEDs location (HDDA back view)

If the amber LED is lit, it indicates a blown fuse. The amber LED is located to the left of the affected fuse, and is viewable through the cutout in the cover plate. Replace the fuse as soon as possible using the procedure in the next section.



Caution: Replace blown fuses with new fuses of the same size, type, and rating. Using the wrong fuse can damage the drive drawer. The fuses are 5 amp, 125 volts, subminiature (Auspex P/N 36-0013).

The procedure that follows describes how to replace a blown fuse.



Tools

- ▲ #1 Phillips screwdriver
- ▲ Antistatic wrist strap
- ▲ Drive drawer key

To remove an HDDA drive drawer fuse

1. Determine which drive drawer has a blown fuse by following the procedure in “To identify a blown fuse.”
2. Put on the antistatic wrist strap and wear it throughout this procedure.



Caution: When handling any components of the NetServer, be sure to use the antistatic wrist strap to prevent electrostatic damage to the equipment.

3. Locate the HDDA drive drawer key, and place it near the NetServer.
4. Gain access to the NetServer on the system console.
5. Enter the **ax_hot_plug** command with the **remove** option, specifying each drive in the affected drawer. For example:
 - ▲ If the fuse is blown for drawer 1 of HDDA 1, and if it contains drives in slots 7 and 8, enter the following command (the example shows the shorthand **rm** for remove):

```
#ax_hot_plug rm 7,8
```

- ▲ If the fuse is blown for drawer 1 of HDDA 1 and the drawer has drives in slots 7 through 13, enter:

```
#ax_hot_plug rm 7-13
```

In either case, the system responds with messages similar to the following:

```
cannot remove device 7.
device 7 is missing.
Press the <RETURN> key when you are finished:
```

6. Disregard the error messages, and press the Return key to “remove” each drive in the affected drawer.
7. Slide the drawer handle to the affected drive drawer.
8. Insert the HDDA drive drawer key, and unlock the drive drawer by turning the key counter-clockwise, as shown in Figure 22.

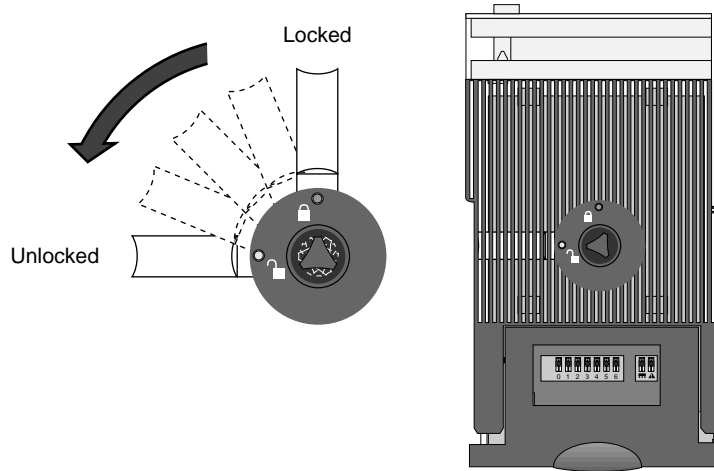

Figure 22. Unlocking the HDDA drive drawer

9. Pull down on the drive drawer handle, and slide the drawer out of the chassis just far enough to access the Disk DCC, as shown in Figure 23.

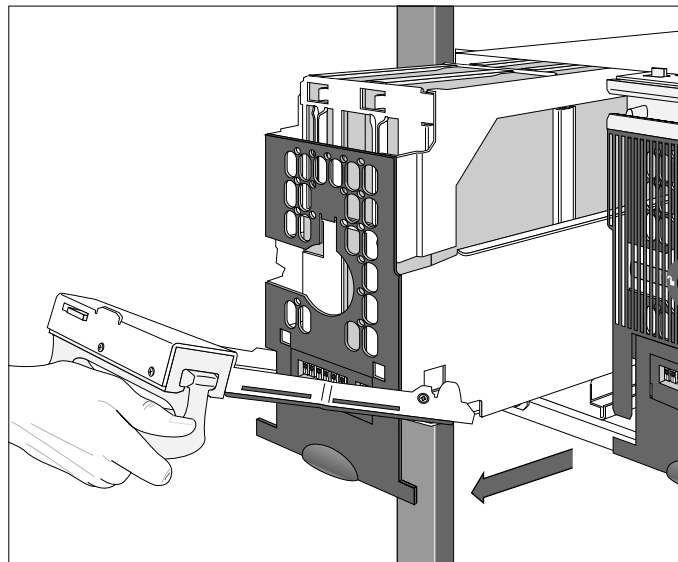

Figure 23. Opening the drive drawer

10. Remove the Disk DCC:
 - a. Release the retaining clip which secures the Disk DCC handle (Figure 14 on page 13).
 - b. Grasp the handle and lift the Disk DCC up and out of the drive slot, and set the DCC aside (Figure 15 on page 14).



Note: It is normal for the Disk DCC to feel tight when removing it from the drive drawer.

11. Move to the back of the NetServer.

12. The cover plate on the back of the HDDA should be detached if you followed step 2 in “To identify a blown fuse.” If it is attached, use a #1 Phillips screwdriver to release it by removing the cover plate screws (Figure 21 on page 19).
13. Slide the cover plate down the power harness to access the fuse.



Warning: Be careful when you work around the back of the HDDA with the cover plate removed. Areas carrying the 48V could cause burns or damage the equipment if shorted to chassis by a metal tool or jewelry.

14. Using your finger tips, remove the blown fuse from the back of the HDDA (the blown fuse is the one to the right of the amber-lit LED).

To replace an HDDA drive drawer fuse

1. Install a new fuse into the empty slot that contained the blown fuse.
2. Replace the Disk DCC:
 - a. Grasp the handle and lower it into the drive slot in the drive drawer (Figure 15 on page 14). Support the disk using your other hand if necessary, but be careful not to touch the PCB connectors.
 - b. Seat the Disk DCC into position by firmly but gently pressing down on the handle. The Disk DCC installs in only one direction. If the Disk DCC does not slide in easily, remove it and try again.
 - c. Secure the handle using the retaining clip provided on the drive drawer. Neither the Disk DCC nor the retaining clip should protrude above the top of the drive drawer.
3. Install the drawer back into the slot by following step 4 through step 10 in “To replace a drive drawer” beginning on page 14.
4. Enter the **ax_hot_plug** command with the **add** option, specifying each drive in the affected drawer. For example:
 - ▲ If the fuse is blown for drawer 1 of HDDA 1, and if it contains drives in slots 7 and 8, enter:
`#ax_hot_plug add 7,8`
 - ▲ If the drawer has drives in slots 7 through 13, enter:
`#ax_hot_plug add 7-13`

In either case, the system responds with messages similar to the following:

```
adding device 7.
All activity on SP0 has been stopped.
Insert or replace the device.
**WARNING** Make sure you insert the drive in the proper slot.
                Otherwise, you may crash the system.
Press the <RETURN> key when you are finished:
```

5. Press the Return key for the first drive in the drawer.

The system responds:

```
adding device 7.
All activity on SP0 has been stopped.
```

Insert or replace the device.

****WARNING**** Make sure you insert the drive in the proper slot. Otherwise, you may crash the system.

Press the <Return> key when you are finished:

6. Continue to press the Return key for every drive in the drawer.
7. After the system has accessed the drive drawer and added the drives, check the fuse LEDs again on the back of the HDDA chassis:
 - ▲ If the fuse LED is not lit, continue with step 8.
 - ▲ If the fuse LED is lit (meaning the replacement fuse has blown), contact Auspex Technical Support for assistance.
8. Move to the front of the NetServer and verify that the drawer LEDs are on:
 - ▲ The drive LEDs should flicker, denoting activity to the drives
 - ▲ The DCC LED should be on, denoting the DCC supply is ok.If the above LEDs are not operating after replacing the fuse, contact Auspex Technical Support for assistance.
9. Once you verify that the drawer and replacement fuse are operating properly, slide the rear cover plate back into its position and secure the cover plate onto the HDDA chassis using the screws you removed in step 12 of the previous procedure.

This completes the procedure for replacing an HDDA fuse.

Power System

This section explains how to remove and replace NS 7000/030 power system field replaceable units (FRUs), and install additional FRUs for system upgrades.

The power system in the NS 7000/030 has five components:

- ▲ 48 VDC bulk power supply
- ▲ Power distribution unit (PDU)
- ▲ Power shelf chassis
- ▲ Disk DC Converter (DCC)
- ▲ Power cables

HDDA Bulk Power Supplies

The bulk power supplies convert 100-240 volt AC power into 48-volt DC power for distribution to the drive drawer Disk DCCs.

The NS 7000/030 storage subsystem supports up to two power shelves with two bulk power supplies in each shelf. You need one bulk power supply for each HDDA chassis in the cabinet, plus an additional bulk power supply in each cabinet for N+1 redundancy. For example, if you have two HDDAs with drive drawers in the storage subsystem, you need four bulk power supplies for N+1 redundancy.

With N+1 redundancy, if one power supply fails, the remaining power supplies keep the NetServer operating. You can then replace the failed power supply without shutting down the NetServer.

Figure 24 shows the location of the power supplies in the storage subsystem.

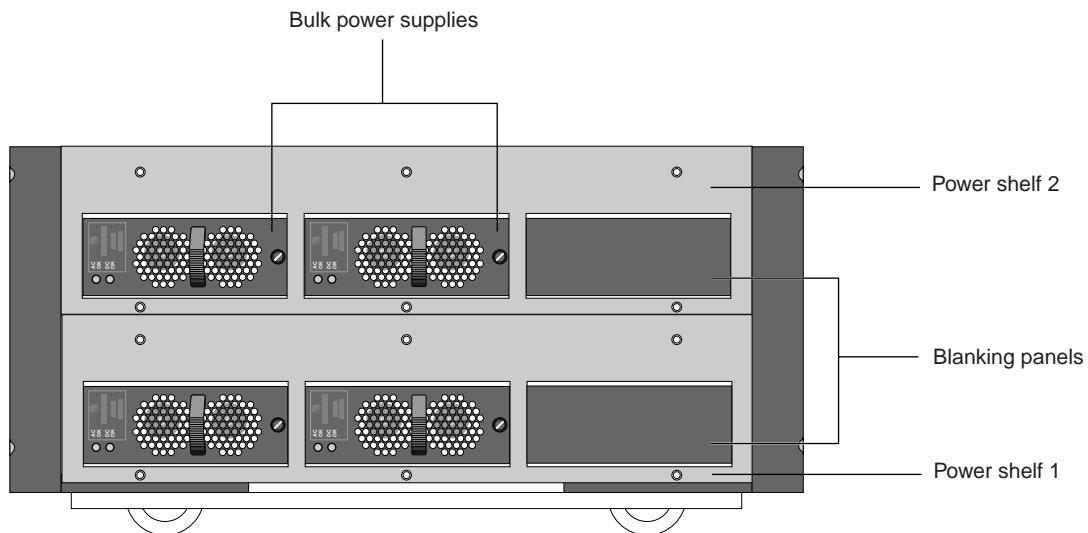

Figure 24. Location of Power Supplies

Bulk Power Supply LEDs

Each bulk power supply has two green LEDs: AC OK and DC OK. During normal operation, the AC OK LED lights to indicate the bulk power supply is receiving AC (mains) power. The DC OK LED lights to indicate the bulk power supply is providing DC power. If either of these LEDs is off, it indicates a power problem. Figure 25 shows the bulk power supply LEDs.

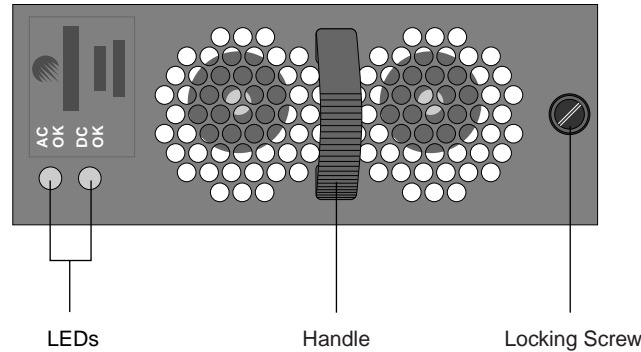

Figure 25. Bulk power supply LEDs



Note: The bulk power supplies have no ON or OFF switch. To power off the base cabinet or storage subsystem, always use the main power switch on the PDU.

Table 1 summarizes the actions required depending on the LED status indicators.

Table 1. Bulk power supply LED status

LEDs	Status	Required Action
AC OK LED on DC OK LED on	Supply is receiving AC power. Supply is distributing DC power.	None.
AC OK LED on DC OK LED off	The power supply module has temporarily failed.	Temporary failure can be caused by the computer room overheating or by blocked air vents around the cabinet and the power supply. Reduce the room temperature, or check the air flow around the supply and clear any blockage. Unplug the supply for 30 seconds, then reseal it to clear the temporary problem.
	The power supply module has failed.	Replace the bulk power supply.
AC OK LED off DC OK LED off	Supply failure.	Check the AC OK LEDs of the other bulk power supplies. If the other power supplies are not receiving AC power, check the AC connections. If the other power supplies are receiving AC power, replace the failed bulk power supply.



Note: In a redundant power supply configuration, the NetServer operates normally if one power supply fails. However, replace the power supply immediately to return to a redundant configuration.

Replacing a Bulk Power Supply

This section describes how to replace a failed bulk power supply in a NS 7000/030 storage subsystem. You can replace a failed bulk power supply without shutting down the NetServer if you have N+1 redundancy, as described on page 24.



Tools

- ▲ Antistatic wrist strap
- ▲ #2 flat-blade screwdriver

To replace a bulk power supply

1. Remove the front bezel from the power module.
2. Put on the antistatic wrist strap, and wear it throughout the procedure.
3. Unpack the replacement bulk power supply.
4. Locate the power supply shelf. Figure 24 on page 24 shows the location of the bulk power supplies.
5. Locate the failed power supply by observing the state of the LED indicators.
6. Unlock the failed power supply by using a #2 flat-blade screwdriver to loosen the locking screw. See Figure 25 on page 25 for the location of the locking screw.
7. Holding the power supply by the handle, pull it forward and slide it out of the chassis.
8. Slide the replacement bulk power supply firmly but gently into its slot until it is seated. There is no click or other audible signal to assure the power supply is properly seated.
9. Lock the bulk power supply into position by using a #2 flat-blade screwdriver to secure the locking screw. Do not overtighten.
10. If the NetServer was powered off during the replacement procedure, power it back on at this time. First power on the storage subsystem, then power on the base cabinet.
11. Make sure the LED status indicators on all of the power supplies are lit.

This concludes the procedure for replacing a bulk power supply.

Adding a Bulk Power Supply

This section describes how to add a bulk power supply to an NS 7000/030 storage subsystem. You can add a bulk power supply without shutting down the NS 7000/030.



Note: Only the two bulk power supply slots on the left side of the power shelf are available for installing bulk power supply modules. The the right-hand slot is inactive and should not be used (Figure 24 on page 24).



Tools

- ▲ Antistatic wrist strap
- ▲ #2 flat-blade screwdriver

To add a bulk power supply

1. Remove the front bezel of the power system module.
2. Put on the antistatic wrist strap, and wear it throughout the procedure.
3. Unpack the new bulk power supply.
4. Locate the power supply shelf (Figure 24 on page 24).
5. Remove the slot cover that is covering the empty slot where you are adding the new power supply. To remove the slot cover:
 - a. Unlock the slot cover by using a #2 flat-blade screwdriver to loosen the locking screw.
 - b. Hold the slot cover by the handle, and pull it forward and out of the slot.
6. Slide the new bulk power supply firmly but gently into its slot until it is seated. There is no click or other audible signal to assure the power supply is properly seated.
7. Lock the bulk power supply into position by using a #2 flat-blade screwdriver to secure the locking screw. Do not overtighten.
8. If the NetServer was powered off during the install procedure, power it back on at this time.
9. Make sure the LED status indicators on all of the power supplies are lit.

This concludes the procedure for adding a bulk power supply.

Power Distribution Unit (PDU)

Power enters the NetServer through the power distribution unit (PDU), which distributes the power to the system. Each power shelf contains one PDU, up to two PDUs per storage subsystem.

This section contains instructions for replacing the PDU.

Replacing a PDU

The PDU is located at the back of the power shelf on the bottom of the storage subsystem. It directs the switchable AC input to the bulk power supply chassis. The PDU has one AC line input cable that attaches to the 2-slot bulk power supply chassis.



Tools

- ▲ #2 Phillips screwdriver

To remove a PDU

1. If the NetServer is running, enter the following command at the root prompt to halt the NetServer's operation:

```
# shutdown -1h +5 "message"
```

where **1** sends the warning message to users who are logged in, **h** halts the HP and causes the server to enter monitor mode, **+5** is the time in minutes before the NetServer operating system comes to a halt, and *message* informs connected clients about the shutdown.

2. Once the monitor prompt (HP>) appears on the screen, turn off the main power switch on the storage subsystem (Figure 26), and then turn off the main power switch on the base cabinet.
3. Unplug the NetServer power cord from the wall receptacle.



Caution: The NetServer power cord must be unplugged prior to replacing the PDU.

4. Release the strain relief clip and unplug the AC power cord on the back of the chassis (Figure 26).

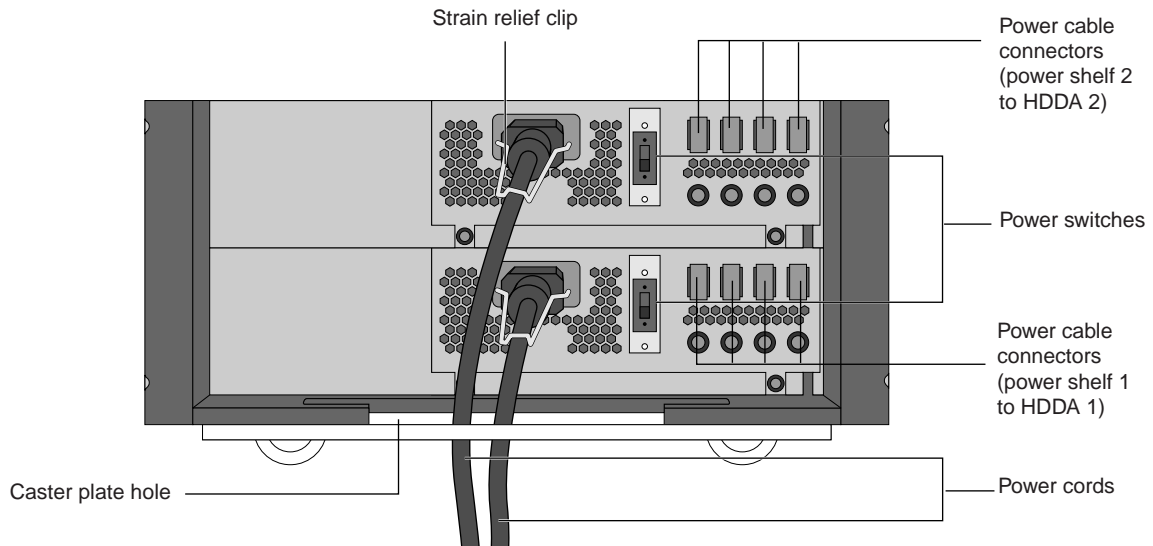

Figure 26. NS 7000/030 power system (back view)

5. Remove the gray power cables from the power cable connectors (Figure 26) on the PDU. The other end of each power cable can remain connected to the HDDA chassis.
6. If removing the PDU in power shelf 1, use a #2 Phillips screwdriver to remove the grounding cable (twisted green and yellow wires) from the PDU.

If removing the PDU in power shelf 2, proceed to the next step.

7. Using a #2 Phillips screwdriver, remove the two screws that mount the PDU to the power shelf (Figure 27).

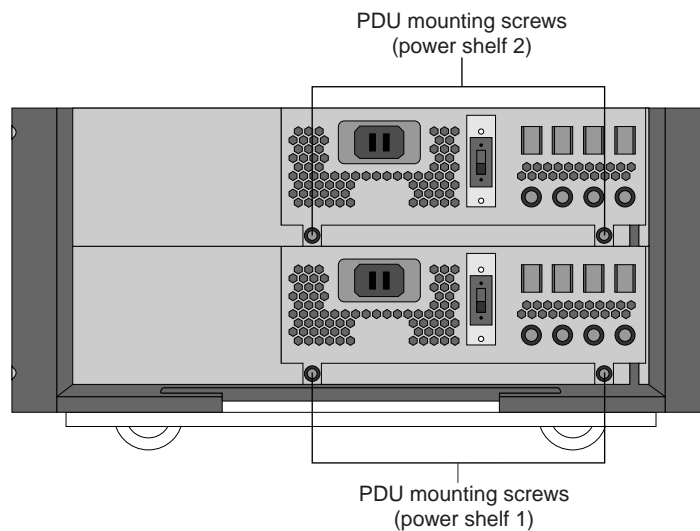

Figure 27. PDU mounting screw locations

8. Remove the failed PDU by sliding it out from the power shelf.

To replace a PDU

1. Slide the new PDU into the power shelf.
2. Verify that the PDU power switch is off.
3. Replace the two screws that secure the PDU to the power shelf (Figure 27).
4. Attach the grounding cable to the chassis using a #2 Phillips screwdriver (PDU in power shelf 1 only).
5. Reconnect the gray power cables to the PDU as follows:
 - ▲ HDDA 1 to power shelf 1
 - ▲ HDDA 2 to power shelf 2See Figure 26 for power cable connector locations.
6. Plug the AC power cord into the power shelf and secure it with the strain relief clip.
7. Plug the other end of the AC power cord into the wall receptacle.
8. Turn on power to the storage subsystem, then the base cabinet.

This concludes the procedure for replacing a PDU.

Power Shelf Chassis

The NS 7000/030 contains up to two power shelves, each with three slots for bulk power supplies. Although each shelf contains three slots, only two are used in each, and the third slot is blank (nonfunctional), as shown in Figure 24 on page 24. Use the procedure in this section for replacing a power shelf chassis.

Replacing a Power Shelf Chassis

You must power off the NetServer when replacing the power shelf chassis.



Note: Each power shelf chassis is mounted independently from the other chassis; therefore, you do not need to remove both to replace a failed chassis. If, however, you are replacing the chassis for power shelf 1, you can remove the power shelf 2 chassis first for easier access and handling, but it is not necessary.



Tools

- ▲ Antistatic wrist strap
- ▲ Antistatic mat
- ▲ #2 Phillips screwdriver
- ▲ #2 flat-blade screwdriver

To remove a power shelf chassis

1. If the NetServer is running, enter the following command at the root prompt to halt the NetServer's operation:

```
# shutdown -lh +5 "message"
```

where **l** sends the warning message to users who are logged in, **h** halts the HP and causes the server to enter monitor mode, **+5** is the time in minutes before the NetServer operating system comes to a halt, and *message* informs connected clients about the shutdown.

After the operating system comes to a halt, the monitor prompt appears on the console terminal screen:

```
HP>
```

2. Turn off the main power to the storage subsystem (refer to Figure 28 for the location of the main power switch for each power shelf), and then turn off the main power to the base cabinet.
3. Remove all bulk power supplies from the failed power shelf and place them on an antistatic mat:
 - a. Unlock the power supply by using a #2 flat-blade screwdriver to loosen the locking screw.
 - b. Hold the power supply by the handle and pull it out of the slot.
4. Remove all slot covers from the failed power shelf and save them for the new installation:
 - a. Unlock the slot cover by using a #2 flat-blade screwdriver to loosen the locking screw.
 - b. Hold the slot cover by the handle and pull it out of the slot.
5. Release the strain relief clip and unplug the AC power cord on the back of the chassis (Figure 28).

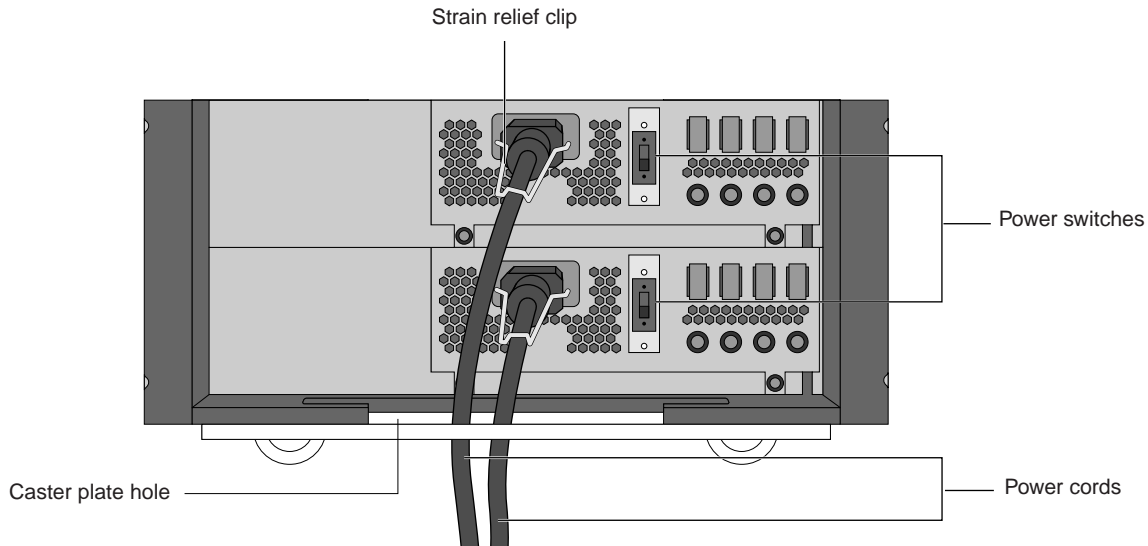

Figure 28. Bulk power supply chassis (back)

6. Remove the gray power cables that supply power to the HDDA.
7. Remove the grounding cable (twisted green and yellow wires) attached to the back of the power shelf chassis (for power shelf 1 only).
8. Remove the plastic side covers surrounding the power shelves.
 - a. Use a small flat-blade screwdriver to pop off the teal snap-catches that hold the plastic covers to the unit (Figure 29). There are a total of eight snap-catches.

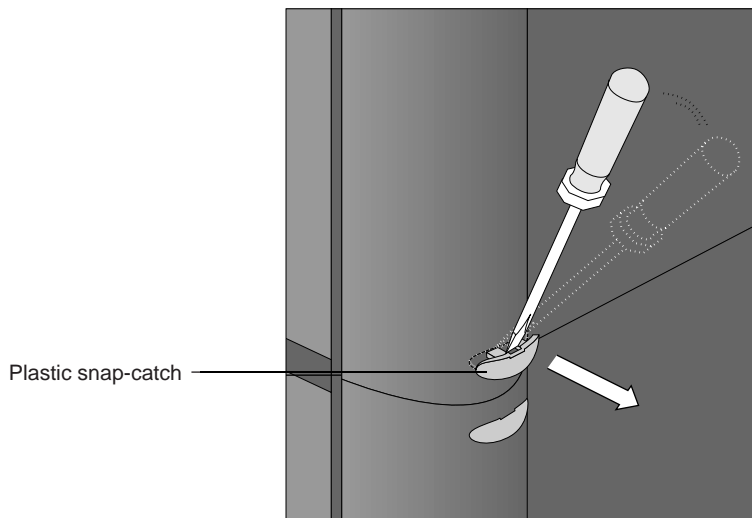

Figure 29. Removing the plastic snap-catch

- b. Using one hand, lift the plastic cover from the curved edge and, using your other hand to hold the bottom edge of the cover, gently pry it off (Figure 30).

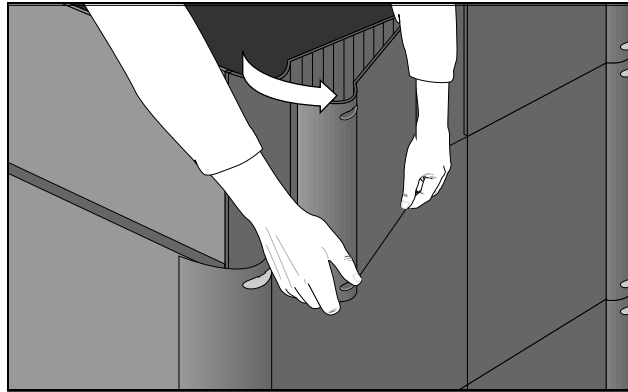

Figure 30. Removing the plastic side covers

- c. Repeat step b until you have removed all four covers. (There are four plastic covers--two on the left side and two on the right.)
9. Using a #2 Phillips screwdriver, remove the four screws (two on each side) that secure the power shelf chassis to the frame. See Figure 31 for screw locations.

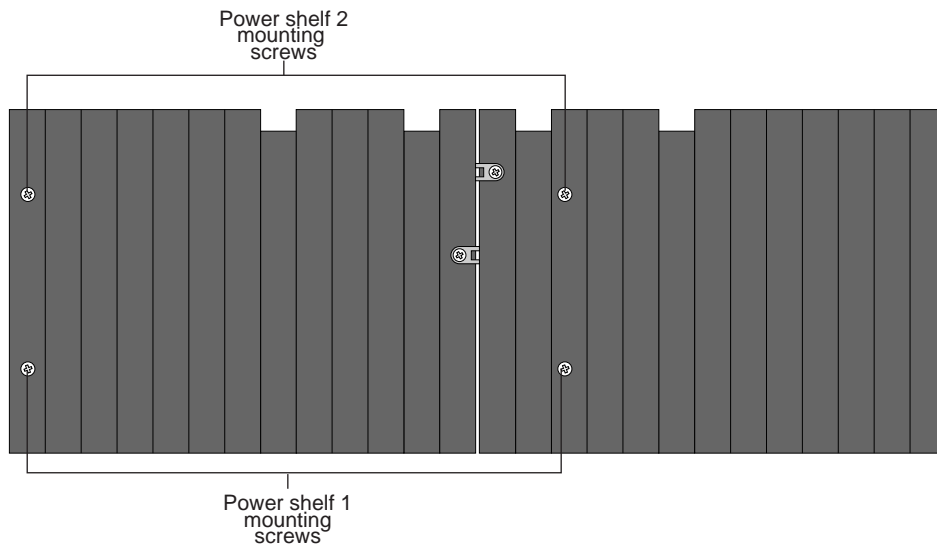

Figure 31. Power shelf chassis screw locations (side view)

10. From the back of the unit, push the power shelf chassis forward to slide it out of the system.
11. Remove the PDU from the failed power shelf chassis. Follow the instructions in step 7 and step 8 starting on page 29 from the procedure "To remove a PDU."

To replace a power shelf chassis

1. Install the PDU that you just removed from the failed power shelf into the replacement power shelf. Use the instructions in step 1 through step 3 in “To replace a PDU” on page 30.
2. Slide the replacement power shelf chassis into its slot and align the screw holes in chassis with the screw holes in the plastic siding.
3. Replace the four screws that your removed in step 9 of the previous procedure to secure the chassis to the frame.
4. Install the plastic side covers, aligning the tabs on each side cover, and snap them into place.
5. Install the eight teal snap-catches by pushing them into their slots. You will hear a click when the snap-catch is installed correctly.



Note: There are four half-joiner pieces at the bottom of the system, one on each corner, that are held into place by the bottom snap-catches. If the half-joiner pieces should come loose, make sure they are in place before replacing the bottom four snap-catches.

6. Attach the power cables from the HDDA to the PDU as follows:
 - ▲ HDDA 1 to power shelf 1
 - ▲ HDDA 2 to power shelf 2

See Figure 26 on page 29 for power cable connector locations.
7. Attach the grounding cable (twisted green and yellow wires) to the power shelf and to the grounding screw on the base of the NS 7000/030 frame.
8. Plug in the AC power cord and secure it with the strain relief clip (Figure 28 on page 32).
9. Install and secure the bulk power supplies:
 - a. Slide the replacement power supply firmly but gently into its slot until it is seated. There is no click or other audible signal to assure the power supply is properly seated.
 - b. Lock the bulk power supply into position by using a #2 flat-blade screwdriver to secure the locking screw.
10. Install the blanking panels and lock them into position by securing the locking screws.
11. Power on the storage subsystem, then the base cabinet.
12. Make sure the LED status indicators on all of the power supplies are lit.

This concludes the procedure for replacing the power shelf chassis.

Disk DC Converter (DCC)

Each HDDA drive drawer requires a single Disk DCC power supply, which converts the 48-volt power from the bulk power supplies into 5-volt and 12-volt power for the disk drives in the drive drawer. Every drive drawer ships from the factory with a Disk DCC power supply installed. The Disk DCC is located in the front right slot of each drive drawer.

Each Disk DCC has one green LED. During normal operation, the LED lights to indicate the Disk DCC is receiving 48-volt power and that the 5 and 12-volt disk drive power supply voltages are operating normally. If the LED is off, the Disk DCC failed or the -48V input power to the drawer has failed.

Figure 32 shows the location of the Disk DCC LED on the drive drawer front panel.

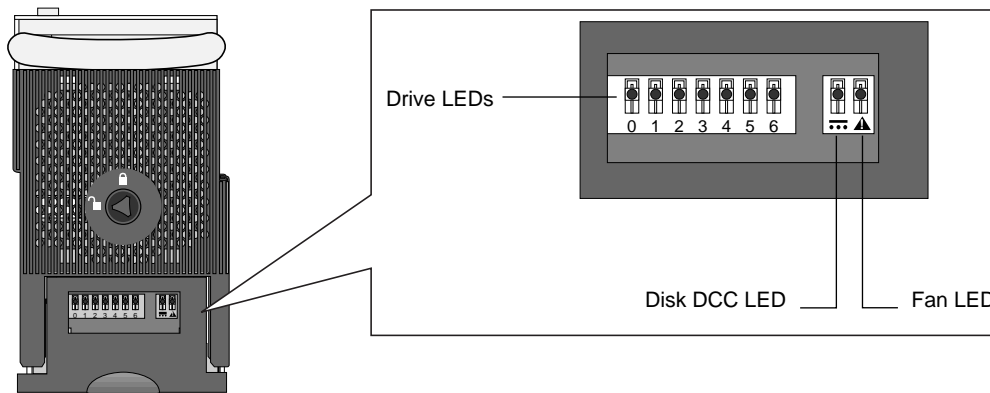

Figure 32. Disk DCC LED (drive drawer front panel)

Table 2 describes the Disk DCC LED.

Table 2. Disk DCC LED status

LED	Status	Required Action
Green LED on	Supply is ok.	None.
Green LED off	Disk DCC failed; no input power to the Disk DCC.	Check the cable connections on the back of the HDDA, check the fuse for the drawer, or replace the Disk DCC. (See page 19 for identifying and replacing a blown drawer fuse.)

Replacing a Disk DCC

The following procedure describes how to replace a Disk DCC. Read the entire procedure before attempting to replace the Disk DCC.

To remove a Disk DCC

1. Put on the antistatic wrist strap, and wear it throughout the procedure.
2. Remove the new Disk DCC from its packing material.
3. Locate the HDDA drive drawer key and unlock the drive drawer by turning the key counter-clockwise, as shown in Figure 33.

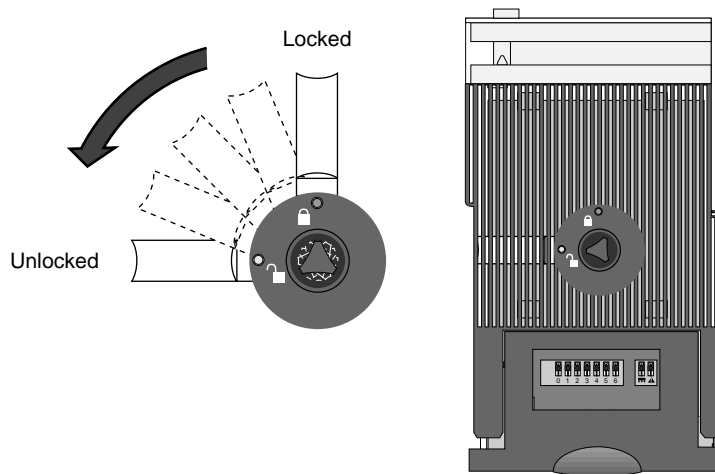

Figure 33. Unlocking the HDDA drive drawer

4. Slide the drawer handle to the selected drive drawer, but do **not** open it yet.
If the NetServer is powered off, proceed to step 9.
5. Gain access to the NetServer on the system console.
6. Enter the `ax_hot_plug` command with the **remove** option to spin down each drive in the affected drawer. For example, if you are replacing the Disk DCC in drawer 1 of HDDA 1, and it has drives in each of its slots, enter the following command (the example shows the shorthand `rm` for remove):

```
#ax_hot_plug rm 7-13
```

The system responds:

```
removing device 7.
All activity on SP0 has been stopped.
Remove the device.
Press the <RETURN> key when you are finished:
```



Caution: Do not press the Return key if the drawer contains only one disk drive.

7. If the drawer contains only one drive, go to step 9.
If the drawer contains more than one drive, continue with step 8.
8. Press the Return key. Do not open the drawer at this time. The system responds:

```
ad7: removed
removed device 7.
removing device 8.
All activity on SP0 has been stopped.
Remove the device.
Press the <RETURN> key when you are finished:
```

Press the Return key for every drive **except the last drive in the drawer**. Using the example in step 6, you would press the Return key specifying each drive until the system prompts you to remove drive 13:

```
removing device 13.
All activity on SP0 has been stopped.
Remove the device.
Press the <RETURN> key when you are finished:
```



Note: Replace the Disk DCC as soon as possible. Until you press the Return key in step 8 of “To replace a Disk DCC,” programs running on the HP wait for I/O operations to complete. This may cause time-outs on clients making NFS requests.

9. Pull down on the drive drawer handle and slide the drawer out of the chassis just far enough to access the Disk DCC (Figure 34).

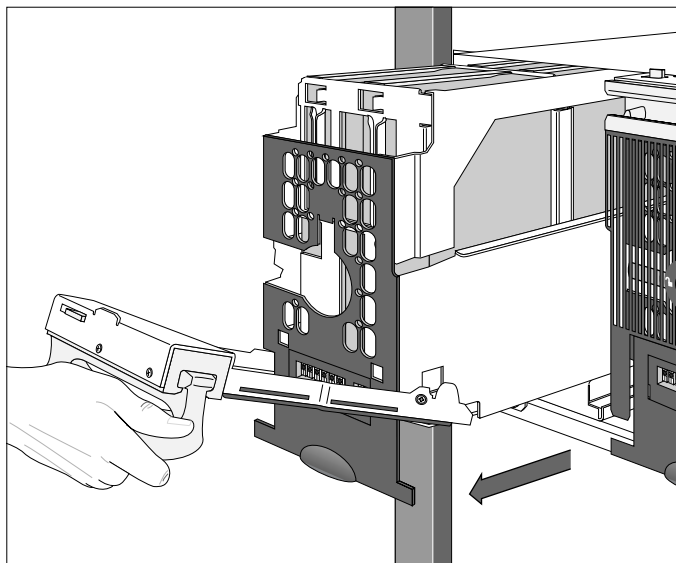

Figure 34. Opening the drive drawer

10. Release the retaining clip that secures the Disk DCC handle (Figure 35).

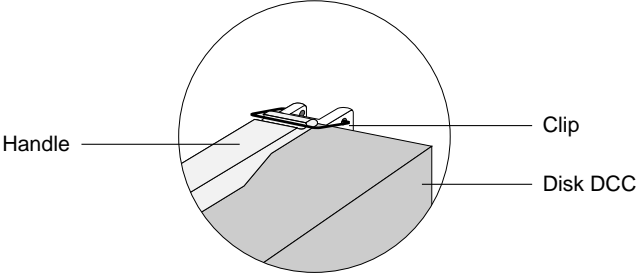

Figure 35. Unlatching the Disk DCC

11. Grasp the handle and lift the Disk DCC up and out of the drive slot (Figure 36), and set it aside.



Note: It is normal for the Disk DCC to feel tight when removing it from the drive drawer.

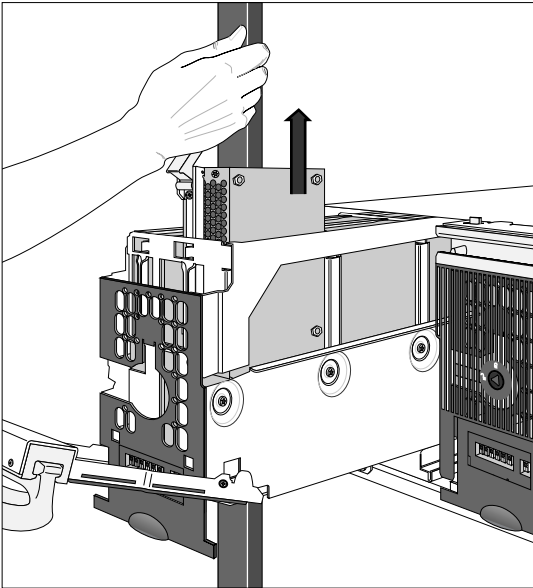

Figure 36. Removing the Disk DCC

To replace a Disk DCC

1. Grasp the replacement Disk DCC by the handle. Using your other hand to support the Disk DCC, lower it into the drive slot in the drive drawer as shown in Figure 37.

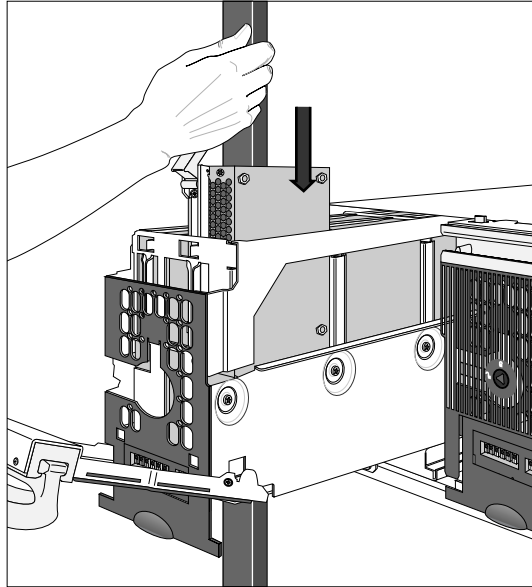

Figure 37. Inserting the Disk DCC

2. Seat the Disk DCC into position by firmly but gently pressing down on the handle.
The Disk DCC installs in only one direction. If the Disk DCC does not slide in easily, remove it and try again.
3. Secure the handle using the retaining clip provided on the drive drawer. Neither the Disk DCC nor the retaining clip should protrude above the top of the drive drawer.
4. Slide the drawer back into the slot until it is about 3/4-inch from the HDDA chassis, as shown in Figure 38.



Note: Be sure that the drawer faceplate is pulled down far enough to allow the cam lever at the bottom of the faceplate to clear the chassis. Once in position, the cam lever provides the cam action that firmly seats the drawer into the chassis once it is closed.

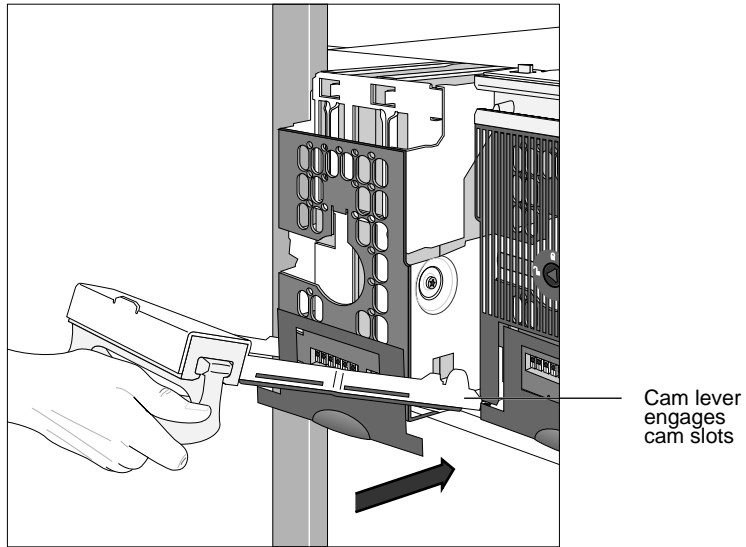

Figure 38. Closing the HDDA drive drawer



Caution: Do not force the drive drawers into the drive drawer slots; doing so will damage the unit.

5. Push the drawer handle up so that the cam lever engages the cam slots in the HDDA chassis (Figure 39).

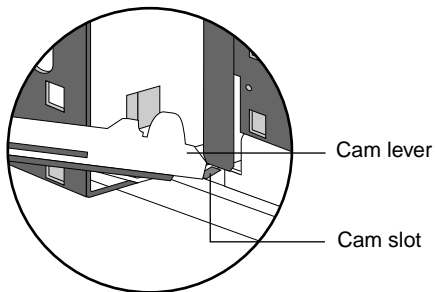

Figure 39. Cam lever engaging in cam slot

6. Seat the drive drawer firmly into the drawer slot by pressing the handle closed (Figure 40). The cam action of closing the handle seats the drive drawer properly.

The drawer latch at the top left corner of the drive drawer clicks into position when the drawer is properly seated.



Caution: Do not force the drive drawers into the slots; doing so will damage the unit. If the drawer is not seated properly, move the handle to release the drawer latch, pull the drawer out, and try again.

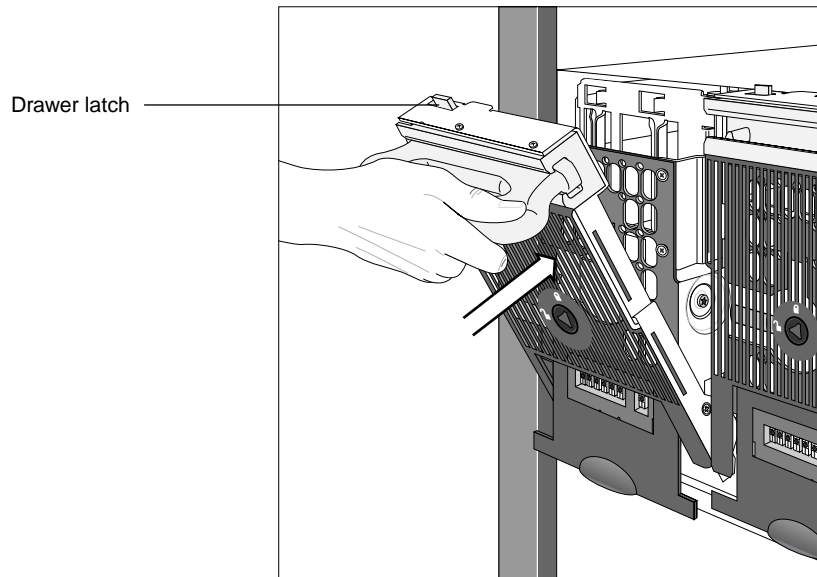

Figure 40. Latching the HDDA drive drawer

7. Insert the drive drawer key and lock the drawer by turning the key clockwise, as shown in Figure 41.

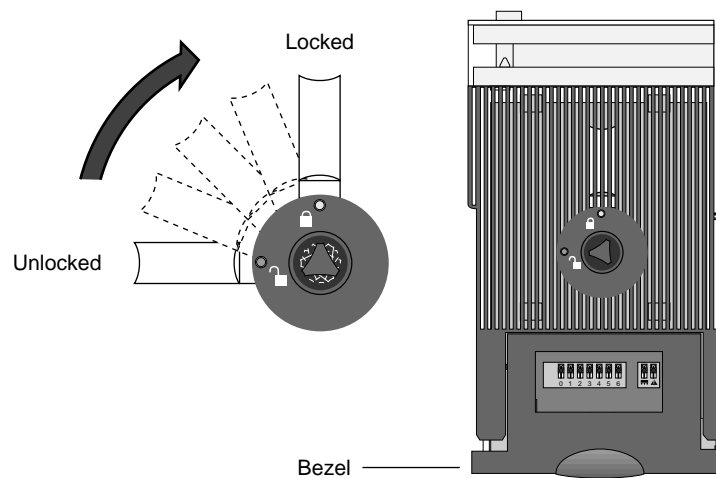

Figure 41. Locking the HDDA drive drawer

8. After the drawer is closed and locked, press the Return key on the system console for the final drive (or only drive) in the **ax_hot_plug** command. The system responds:

```
ad13: removed
removed device 13.
```

9. Enter the **ax_hot_plug** command with the **add** option, specifying each drive in the affected drawer. For example, if you are replacing the Disk DCC in drawer 1 of HDDA 1, enter:

```
#ax_hot_plug add 7-13
```

The system responds:

```
adding device 7.
All activity on SP0 has been stopped.
Insert or replace the device.
**WARNING** Make sure you insert the drive in the proper slot.
           Otherwise, you may crash the system.
Press the <RETURN> key when you are finished:
```

10. Press the Return key for each drive in the drawer. For each drive, the system responds that the drive is added. For example:

```
ad7: <Auspex 9GB cyl 8668 alt 1 hd 16 sec 128>
added device 7.
```

11. Check that the DCC LED in the drive drawer is on, indicating normal operation.

This completes the procedure for replacing a Disk DCC.

Maintenance

This section provides maintenance procedures for the HDDA fans and SCSI cables.

Checking and Replacing a Fan

Make sure all NetServer fans are operational whenever you visit a customer site. Fans are essential to keep the temperature and air flow at the optimal levels inside the NetServer cabinet. The HDDA chassis fans in the NS 7000/030 are visible and accessible from the back of the storage subsystem. Make sure there is air flow from the fan by placing your hand in front of each fan.

Additionally, each HDDA drive drawer has a fan LED (visible from the front). During normal operation, the LED is off. The amber LED lights when a fan is not operating correctly. If an HDDA fan needs replacement, follow the procedures in the next section.

To identify a faulty fan

1. Observe the fan LED on the front of the HDDA (Figure 42). If a fan LED is lit, replace the fan using the procedure in the following section.
2. Remove the rear bezel of the HDDA and observe the speed of the fans. They should all be spinning at approximately the same speed. If one or all of the fans have slowed down or stopped, replace the fan.

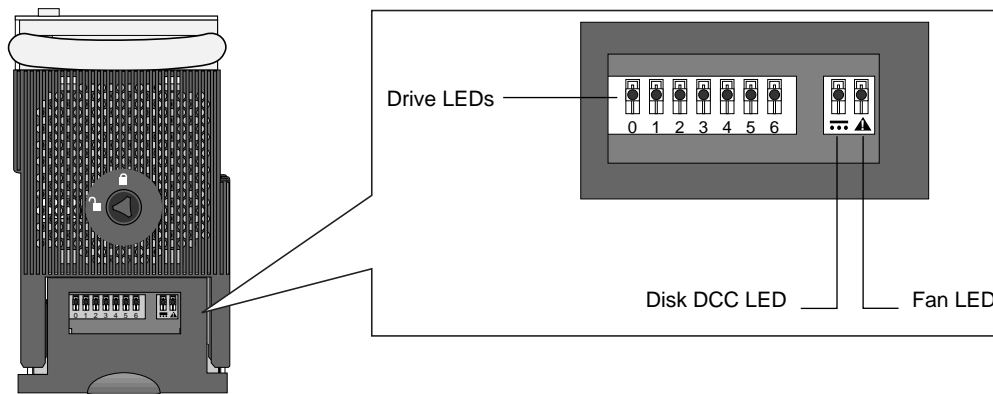

Figure 42. Location of fan LED

Replacing an HDDA Fan

If the fan LED is lit, it means that the speed of the fan has fallen below the acceptable RPM and may soon fail, or that it has already failed. In either case, the fan should be replaced.



Tools

- ▲ #1 Phillips screwdriver
- ▲ Antistatic wrist strap

To remove an HDDA fan

1. Remove the rear bezel of the HDDA and put on the antistatic wrist strap.



Caution: When handling any components of the NetServer, be sure to use the antistatic wrist strap to prevent electrostatic damage to the equipment.

2. Using a #1 Phillips screwdriver, remove the two screws that secure the fan to the chassis (Figure 43).



Caution: Remove only the two upper screws securing the fan to the chassis. Do not remove the screws that secure the finger guard to the fan.

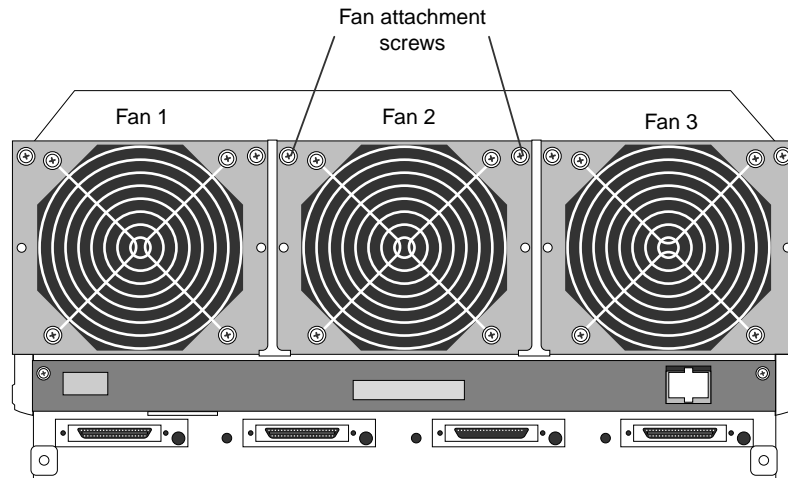

Figure 43. Location of HDDA fans (back of HDDA chassis)

3. Tilt the fan out slightly, and lift the fan up and out of its slot at the bottom of the chassis.
4. Unplug the fan power cable from the chassis.

To replace an HDDA fan

1. Remove the new fan from its packaging.
2. Plug the power cable on the fan into the chassis.
3. Place the fan into its slot in the chassis.
4. Tilt the fan slightly outward, and using your fingers, move the power wires aside to prevent them from being crimped.
5. Push the fan forward, being careful not to crimp the wires, and secure it to the chassis by replacing the two screws.
6. Move to the front of the NetServer and verify that all fan LEDs are off.

This completes the procedure for replacing an HDDA fan.

Replacing SCSI Cables

There is a one-to-one correspondence between the drive drawers and SCSI cables in the NS 7000/030. If you suspect a SCSI cable has failed, use the following procedure and reference figures to replace the SCSI cable.

The NetServer does not need to be powered off before replacing a SCSI cable. Additionally, you do not need to spin down each of the drives in the affected drawer. You do, however, need to suspend activity on the failed SCSI channel before replacing the cable. Read the procedures thoroughly before replacing a SCSI cable.



Tools

- ▲ SCSI cable assembly, 8ft. (part number 45-0280)
- ▲ SCSI cable assembly, 6ft. (part number 45-0349)
- ▲ Antistatic wrist strap

To replace SCSI cables on the storage subsystem

1. Open the NetServer and put on the antistatic wrist strap.
2. Using Figure 44 on page 46, locate the failed SCSI cable for the drive drawer.
3. If the NetServer is running, gain access to the system console.
4. Enter the **ax_hot_plug** command with the **replace** option to suspend I/O activity for the channel of the failed SCSI cable.

For example, if the SCSI cable to drawer 1 of HDDA 1 fails, halt activity to this cable by entering:

```
#ax_hot_plug replace 7
```

where 7 is any drive in that drawer.

The system pauses activity to the SCSI channel (in the example, activity on SP0) and displays messages similar to the following:

```
removing device 7.  
All activity on SP0 has been stopped.  
Insert or replace the device.  
**WARNING** Make sure you insert the drive in the proper slot.  
                Otherwise, you may crash the system.  
Press the <RETURN> key when you are finished:
```



Note: Do not press the Return key. At this stage the SCSI channel activity is suspended, and you may replace the cable. Do not open the drawer.

5. Unscrew and remove the SCSI cable from the SCSI port on the affected drive drawer.
6. Unscrew and remove the SCSI cable from the SP.
7. Cut the tie wraps as necessary to remove the SCSI cable from the cabinet.
8. Remove the new SCSI cable from its packaging and connect one end of the SCSI cable to the SCSI port on the affected drive drawer.
9. Route the new SCSI cable into the storage subsystem as the old SCSI cable was routed.
10. Secure the cable with tie-wraps as required.
11. Connect the open end of the SCSI cable to the appropriate location on the SP.
12. Reactivate I/O activity to the SCSI channel by pressing the Return key.

The system restarts activity on the SCSI channel (in the example, activity to SP0) and displays messages similar to the following:

```
ad7: <Auspex 9GB cyl 8668 alt 1 hd 16 sec 128>
added device 7.
```

This completes the procedure for replacing SCSI cables.

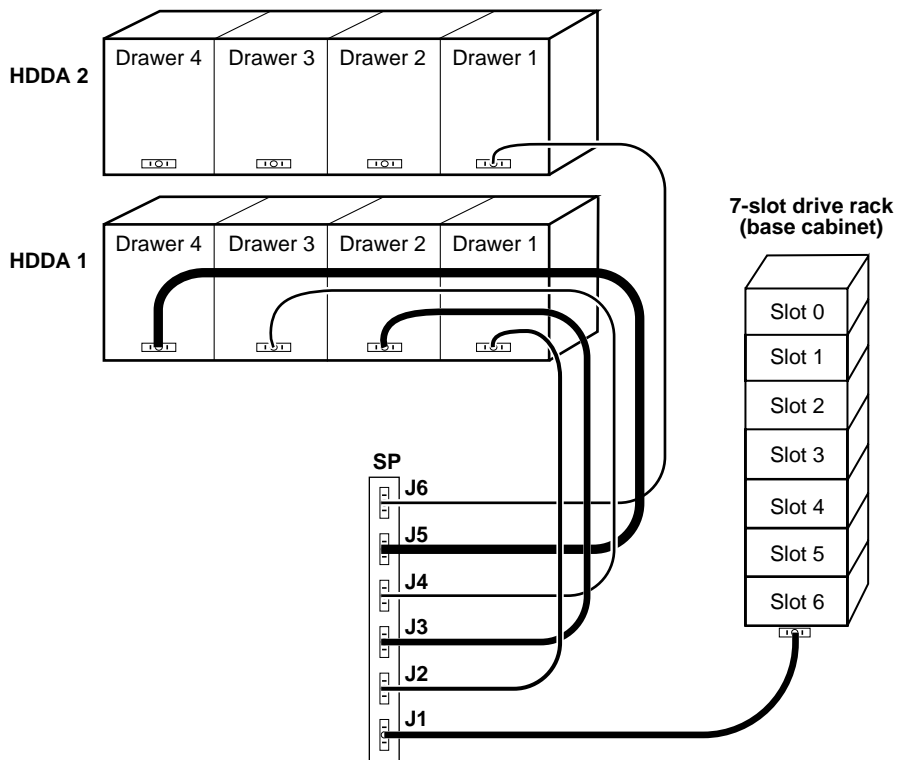

Figure 44. Example SCSI cabling for NS 7000/030 (back view)

HDDA Monitoring Board

The HDDA monitoring board provides a tool that service personnel can use to take measurements inside the HDDA drive drawers. The monitoring board provides current status via messages that appear on a terminal screen (or PC laptop) once the monitoring board is installed and connected.

Installing an HDDA Monitoring Board

The components of the HDDA monitoring board include the monitoring board and a cable that has an RJ45 connection on one end and an RS232 connection on the other end. The board can be installed while the NetServer is running. This section describes how to install an HDDA monitoring board.



Tools

- ▲ #1 Phillips screwdriver
- ▲ Antistatic wrist strap
- ▲ Terminal with keyboard (or PC laptop)

To install an HDDA monitoring board

1. Open the back door of the NetServer and put on the antistatic wrist strap.
2. Remove the HDDA monitoring board from its packaging.
3. Use a #1 Phillips screwdriver to remove the two screws that secure the rear cover plate to the HDDA chassis.
4. Slide the cover plate down the power harness to gain access to the monitoring board port. The monitoring board port is on the left-most side of the HDDA chassis when viewed from the back (Figure 45).

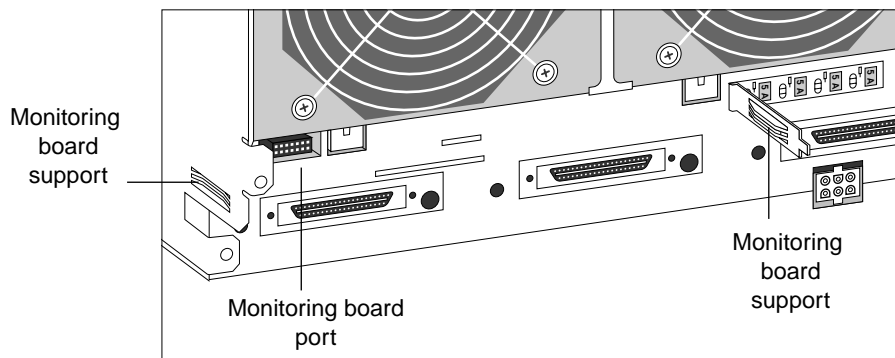

Figure 45. HDDA monitoring board location



Warning: Be careful when you work around the back of the HDDA with the cover plate removed. Areas carrying the 48V could cause burns or damage the equipment if shorted to chassis by a metal tool or jewelry.

5. Locate the monitoring board cable and thread the RJ45 connector end through the cut-out in the cover plate.
6. Connect the RJ45 end into one of the RJ45 ports on the monitoring board. It does not matter which port you choose.
7. While holding onto the cable and using the RJ45 connection for support, gently slide the board into position. Do not force the board into position.

The board should slide into the middle of the monitoring board supports, as shown in Figure 46.

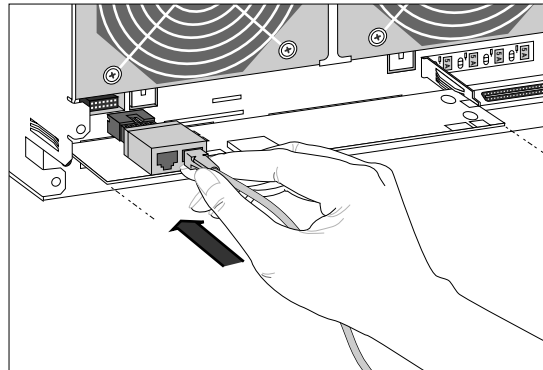

Figure 46. Installing the HDDA monitoring board

8. Push against the connector to seat the board.



Warning: Do not touch the PCB components on the top or bottom of the board. Once the board is installed, it will be carrying 48V current. If you need to use your fingers to seat the board, press *only* against the edges of the board.

9. After the board is in position, reattach the rear cover plate.
10. Connect the cable's RS232 end into a serial port on a terminal or PC laptop.



Note: You can also use the system console by disconnecting it from the HP. However, messages to and from the HP will not be captured while the system console is being used for HDDA readings.

11. Press the Return key.

The monitoring board sends messages to the terminal, and data similar to the following appears on the screen:

```
Drawer A  Type=SE      48V=Good  DCC=Good  Drawer Closed
          Vcc=5.05     V12=12.00 VBS=5.05  Vid=0.28
          Fan3(H)=2520 Temp=22.5

Drawer B  Type=SE      48V=Good  DCC=Good  Drawer Closed
          Vcc=5.05     V12=12.00 VBS=5.05  Vid=0.45
          Fan2(H)=2520 Temp=22.5

Drawer C  Type=SE      48V=Good  DCC=Good  Drawer Closed
          Vcc=5.05     V12=12.00 VBS=5.05  Vid=0.70
          Fan1(H)=2520 Temp=22.5

Drawer D  Type=SE      48V=Good  DCC=Good  Drawer Closed
          Vcc=5.05     V12=12.00 VBS=5.05  Vid=1.00
          Fan1(H)=2520 Temp=22.5

HDDA EM   Temp=18.5
```

12. After you install the board and view the monitoring board messages, you can disconnect the cable.

This concludes the procedure for installing an HDDA monitoring board. The next section describes how to interpret the monitoring board messages.

HDDA Monitoring Board Messages

The HDDA monitoring board provides current status of the drive drawers, including power supply voltages, fan speed, temperature inside the drawer, and drawer condition (open or closed). The board also provides status on how it is functioning by displaying its current temperature and any detected errors.

When you connect the cable to the monitoring board and press the Return key, messages appear as one screen of data similar to the following (the meaning of the listed specifications is displayed in Table 3 on page 51).

```

Drawer A  Type=SE      48V=Good  DCC=Good  Drawer Closed
          Vcc=5.05     V12=12.00 VBS=5.05  Vid=0.28
          Fan3(H)=2520 Temp=22.5

Drawer B  Type=SE      48V=Good  DCC=Good  Drawer Closed
          Vcc=5.03     V12=12.00 VBS=5.08  Vid=0.45
          Fan2(H)=2520 Temp=21.5

Drawer C  Type=SE      48V=Good  DCC=Good  Drawer Closed
          Vcc=5.03     V12=11.94 VBS=5.08  Vid=0.70
          Fan1(H)=2460 Temp=21.5

Drawer D  Type=SE      48V=Good  DCC=Good  Drawer Closed
          Vcc=5.05     V12=11.94 VBS=5.08  Vid=1.00
          Fan1(H)=2460 Temp=21.0

HDDA EM   Temp=18.5
    
```

The monitoring board identifies the drawers in the HDDA chassis as Drawer A through D. Drawer A is the first drawer on the left side of the chassis (when viewed from the front). The fans are numbered Fan 1 to Fan 3, and their location is shown in Figure 47.

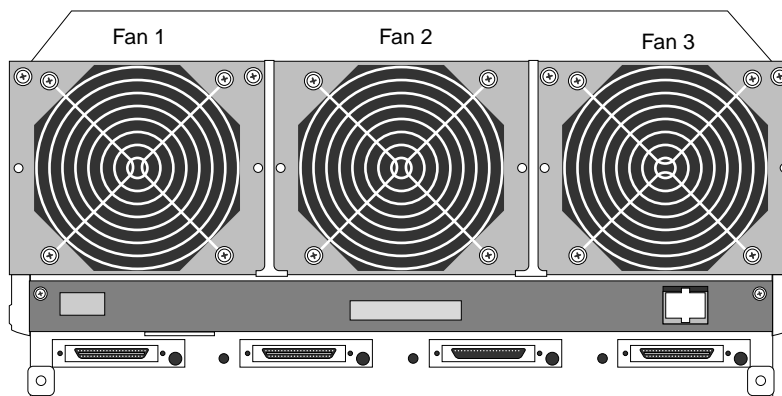

Figure 47. HDDA fan numbers

Table 3. HDDA monitoring board specification list

Specification	Meaning
Type=SE	Single ended
Vcc=	+5V power supply voltage
V12=	+12V power supply voltage
VBS=	Bias supply voltage that powers the monitoring board
Vid=	Used by Auspex test engineering
Fan#(H)=	The fan speed in RPMs (the H specifies high-speed) 2600 rpm is ideal; anything above 1300 is acceptable
Temp=	The current temperature inside the drive drawer, specified in degrees C
HDDA EM Temp=	The current temperature of the monitoring board

HDDA Drawer Error Messages

If the monitoring board detects an error inside one of the drive drawers or an error with its own operation, an error message appears on the terminal screen. The message is displayed to the right of the **Temp=** reading.

The error messages are displayed as **ERROR=0xnn**, where *nn* equals the error code. For example, if a problem is detected in Drawer A, an error message such as the following may appear:

```

Drawer A  Type=SE      48V=Good  DCC=Good  Drawer Closed
          Vcc=5.05    V12=12.00 VBS=5.05  Vid=0.28
          Fan3(H)=2520 Temp=22.5  ERROR=0x01 ← Error message

Drawer B  Type=SE      48V=Good  DCC=Good  Drawer Closed
          Vcc=5.03    V12=12.00 VBS=5.08  Vid=0.45
          Fan2(H)=2520 Temp=21.5

Drawer C  Type=SE      48V=Good  DCC=Good  Drawer Closed
          Vcc=5.03    V12=11.94 VBS=5.08  Vid=0.70
          Fan1(H)=2460 Temp=21.5

Drawer D  Type=SE      48V=Good  DCC=Good  Drawer Closed
          Vcc=5.05    V12=11.94 VBS=5.08  Vid=1.00
          Fan1(H)=2460 Temp=21.0

HDDA EM  Temp=18.5

```

Using the definitions in Table 4, the **ERROR=0x01** message means “last drawer command failed.” If the error message was “brownout-reset,” the message would be **ERROR=0x40**.

Table 4 shows the values and error type represented by each digit. Table 5 on page 53 provides a further description of each error. Both tables need to be used to decipher the exact nature of the detected problem.

Table 4. HDDA drawer error codes

First Digit Value	Error Type	Second Digit Value	Error Type
0x0_	No error detected	0x_0	No error detected
0x1_	ADC non-functional	0x_1	Last drawer command failed
0x2_	ADC time-out	0x_2	Watchdog-reset
0x3_	ADC time-out and ADC non-functional	0x_3	Watchdog-reset and last drawer command failed
0x4_	Brownout-reset	0x_4	Output port failed
0x5_	Brownout-reset and ADC non-functional	0x_5	Output port failed and last drawer command failed
0x6_	Brownout-reset and ADC time-out	0x_6	Output port failed and watchdog-reset
0x7_	Brownout-reset and ADC time-out and ADC non-functional	0x_7	Output port failed and watchdog-reset and last drawer command failed
0x8_	I ² C comm failure	0x_8	Timer 0 failed
0x9_	I ² C comm failure and ADC non-functional	0x_9	Timer 0 failed and last drawer command failed
0xA_	I ² C comm failure and ADC time-out	0x_A	Timer 0 failed and watchdog-reset
0xB_	I ² C comm failure and ADC time-out and ADC non-functional	0x_B	Timer 0 failed and watchdog-reset and last drawer command failed
0xC_	I ² C comm failure and brownout-reset	0x_C	Timer 0 failed and output port failed
0xD_	I ² C comm failure and brownout-reset and ADC non-functional	0x_D	Timer 0 failed and output port failed and last drawer command failed
0xE_	I ² C comm failure and brownout-reset and ADC time-out	0x_E	Timer 0 failed and output port failed and watchdog-reset
0xF_	I ² C comm failure and brownout-reset and ADC time-out and ADC non-functional	0x_F	Timer 0 failed and output port failed and watchdog-reset and last drawer command failed

Table 5. HDDA drawer error descriptions

Error Name	Description
ADC non-functional	Indicates that the analog-to-digital converter on the addressed drawer is not functioning and the HDDA drawer needs to be replaced.
ADC time-out	If the ADC is functioning, this error indicates that an analog input signal on the addressed drawer so exceeded its upper bounds that a conversion could not be accomplished. If this happens more than once an hour, it probably indicates a fault in the HDDA drawer.
Brownout-reset	The HDDA monitoring processor experienced a drop in the VBS supply that caused the processor to reset itself. All previous settings of SCSI high address line, SCSI termination, RC5 usage and voltage margining were lost and need to be restored if different from their default values.
I ² C comm failure	Since the last diagnostic reading, there was a failure of four consecutive attempts to communicate to a drawer over the I ² C bus and the previously reported data is not necessarily valid. When there is an I ² C failure, the returned data is always all zeros. This may be caused by a bad HDDA drawer, a bad HDDA monitoring processor, a bad umbilical cable, an incorrectly installed umbilical cable, or a bad HDDA backplane.
Last drawer command failed	Some command sent to the addressed drawer since the last time the diagnostic reading was not valid or had additional bytes sent with it; the desired operation was not performed. If this happens more than once an hour, it probably indicates a fault in the HDDA drawer, a problem with the umbilical cable, or a problem in the HDDA backplane.
Watchdog-reset	The HDDA monitoring processor in the addressed drawer experienced a condition of software insanity which caused the processor to reset itself. All previous settings of SCSI high address line, SCSI termination, RC5 usage and voltage margining were lost and need to be restored if different from their default values.
Output port failed	This error indicates that the HDDA monitoring processor on the addressed drawer attempted to change one of its output signals, but when that pin was read back, it did not have the expected value. If this happens more than once, it indicates a fault in the HDDA drawer.
Timer 0 failed	This error indicates that the timer counter on the addressed drawer which is used for flashing LEDs is not functioning and the monitoring board processor needs to be replaced.

HDDA Monitoring Board Error Messages

The monitoring board can also detect problems with its operation. If an error occurs, an error message is displayed to the right of its **Temp=** reading at the bottom of the screen, as shown below:

Drawer A	Type=SE	48V=Good	DCC=Good	Drawer Closed
	Vcc=5.05	V12=12.00	VBS=5.05	Vid=0.28
	Fan3(H)=2520	Temp=22.5		
Drawer B	Type=SE	48V=Good	DCC=Good	Drawer Closed
	Vcc=5.03	V12=12.00	VBS=5.08	Vid=0.45
	Fan2(H)=2520	Temp=21.5		
Drawer C	Type=SE	48V=Good	DCC=Good	Drawer Closed
	Vcc=5.03	V12=11.94	VBS=5.08	Vid=0.70
	Fan1(H)=2460	Temp=21.5		
Drawer D	Type=SE	48V=Good	DCC=Good	Drawer Closed
	Vcc=5.05	V12=11.94	VBS=5.08	Vid=1.00
	Fan1(H)=2460	Temp=21.0		
HDDA EM	Temp=18.5	ERROR=0x01	← Error message	

Using the definitions in Table 6 on page 55, the **ERROR=0x01** message means “bad last serial command.” If the error message was “buffer error, I²C start failed,” the message would be **ERROR=0x24**.

Table 6 shows the values and error type represented by each digit. Table 7 on page 56 provides a further description of each error. Both tables need to be used to decipher the exact nature of the detected problem.

Table 6. Monitoring board error codes

First Digit Value	Error Type	Second Digit Value	Error Type
0x0_	no error detected	0x_0	no error detected
0x1_	buffer overflow	0x_1	bad last serial command
0x2_	buffer error	0x_2	bad ADC value
0x3_	buffer error and buffer overflow	0x_3	bad ADC value and bad last serial command
		0x_4	I ² C start failed
		0x_5	I ² C start failed and bad last serial command
		0x_6	I ² C start failed and bad ADC value
		0x_7	I ² C start failed and bad ADC value and bad last serial command
		0x_8	serial framing error
		0x_9	serial framing error and bad last serial command
		0x_A	serial framing error and bad ADC value
		0x_B	serial framing error and bad ADC value and bad last serial command
		0x_C	serial framing error and I ² C start failed
		0x_D	serial framing error and I ² C start failed and bad last serial command
		0x_E	serial framing error and I ² C start failed and bad ADC value
		0x_F	serial framing error and I ² C start failed and bad ADC value and bad last serial command

Table 7. Monitoring board error descriptions

Error Name	Description
Buffer overflow	Serial data is collected into a 32-byte buffer; if the buffer has 31 bytes already and one more byte is received, then this flag is set and the last received serial data is not saved.
Buffer error	Serial data is collected into a 32-byte area in the monitoring board's processor memory; pointers are used to determine where data is to be written to and read from. If either of these pointers ever point outside of this 32-byte block, then this error flag is set and the pointers are restored to proper places, losing any serial data left in the buffer.
Bad last serial command	If the monitoring board receives any serial data other than allowed commands, then the bad data is disregarded and this flag is set to indicate the error.
Bad ADC value	Whenever an analog-to-digital conversion is performed, if the resulting value is much greater than expected, or if the converter times out before it finishes a conversion, this flag is set and the suspect reading is disregarded. If this error occurs more than once an hour, then the HDDA monitoring board needs to be replaced.
I ² C start failed	Communications with all the HDDA drawers depends on proper functioning of the I ² C bus. If there is a fundamental fault on the I ² C bus, then communication to any drawer is not possible. This flag is set anytime such a fault condition is detected.
Serial framing error	Serial data is expected to conform to the specifications of 9600 baud with one start bit, eight data bits, no parity, and one stop bit. If the serial signal level is wrong during the expected stop bit, this error flag is set and the serial data is rejected.

Unresolved Drawer Slot Number Messages

The drawer slot and position is determined by the voltage of one signal on the umbilical cable. If there is a flaw or failure on the HDDA backplane, in the umbilical cable, or on the HDDA motherboard, the drawer slot and position information is unavailable to the monitoring board. When this happens, one of the following two messages will appear at the beginning of the monitoring board's display of data:

```
Drawer or Backplane    Open    Vid=0.xx
Drawer or Backplane    Bad     Vid=y.yy
```

If either of these messages appear, check all the cable connections on the umbilical cable, and ensure that the drawer and tray is fully inserted. If these items are correct, you will need to replace the HDDA drawer or replace the HDDA chassis.

Field Service Information

This section provides descriptions and part numbers for field replacement of components in the NS 7000/030 storage subsystem. Table 8 contains a list of recommended tools and Table 9 lists FRU part numbers.

Tools Needed for Replacement Procedures

Table 8 provides a list of tools you will need to install or replace components and indicates typical operations where they are used. These tools are also identified within the specific procedures throughout this guide.

Table 8. HDDA installation and replacement tools

Type	Where used
Antistatic mat	Swapping boards or components
#1 Phillips screwdriver	Releasing rear cover plate Replacing fan
#2 Phillips screwdriver	Installing HDDA chassis Replacing power shelf chassis
#2 flat-blade screwdriver	Replacing power supply
3/32-inch Allen driver	Securing drive drawers

FRU Part Numbers

Table 9 lists and describes components and part numbers for the NS 7000/030 components. Other components within the base cabinet, such as processors, SBus and memory modules, filters, and cables, are the same as the NS 7000/250 NetServer. The FRU part numbers for these components can be found in the *1.9 Field Service Guide*.

Table 9. FRU part numbers

Part number	Description
50-0705	HDDA chassis
50-0707	HDDA drive drawer
50-0782	HDDA disk drive
50-0783	HDDA DCC disk
36-0013	HDDA 5A, 125V drawer fuse
45-0314	HDDA 48V power cable
65-0024	48V bulk power supply
64-0154	48V bulk power shelf chassis, 3-slot
69-0005	PDU, 2-slot
45-0335	Power cord, 13A 200-240 VAC, North America
45-0337	Power cord, 15A 100 VAC, Japan
45-0349	SCSI cable assembly, 6 ft.
45-0280	SCSI cable assembly, 8 ft.
10-0168	HDDA monitoring board
50-0706	HDDA chassis fan

Index

Numerics

48 VAC power supplies 24

A

AC power cord connector 29
adding
 drive drawer 17 to 18
 power supply, 48 VAC 27

B

bulk power supplies
 See power supply

C

cover plate, HDDA 4

D

Disk DCC 35
 LEDs 35
 replacing 36 to 42
disk drive
 numbering 9
drive drawer
 adding 17 to 18
 LEDs 7, 19
 numbering 10
 replacing 9 to 17
 replacing a fuse 18 to 23
drive drawer fuse location 19

F

field service information 57
FRU part numbers 57

H

HDDA

adding a drive drawer 17 to 18
checking a fan 43
components 3
cover plate 4
disk drive numbering 9
drive drawer
 error messages 51
 locking 16, 41
 replacing the fuse 18 to 23
 unlocking 11, 36
fan replacement 43 to 44
LEDs 7, 19
location 2
monitoring board 47
 error messages 54
 installing 47 to 49
 messages 50
 specification list 51
mounting screws 6
plastic side covers 5
power supplies 24
replacing 3 to 8

I

installing a monitoring board 47 to 49

L

LEDs

Disk DCC 35
drive drawer 7, 19
drive drawer fuse 19
HDDA 7, 19
power supply 8, 25
locking the HDDA drive drawer 16, 41

M

- maintenance procedures 43
- monitoring board
 - error messages 54
- mounting screws
 - HDDA chassis 6
 - PDU 29
 - power shelf 33

N

- N+1 redundancy 24
- NS 7000/030
 - back view 2
 - drive drawer numbering 10
 - field service information 57
 - front view 2
 - HDDA monitoring board 47
 - maintenance 43
 - power shelf 31
 - power supplies 24
 - power system 24 to 42
 - power system, back view 29
 - SCSI cabling example 46

P

- part numbers, FRUs 57
- PDU 28
 - location 29
 - mounting screws 29
 - replacing 28 to 30
- power cable connectors 29
- power distribution unit
 - See PDU
- power shelf 31
 - location 2, 24
 - mounting screws 33
 - removing plastic covers 32
 - replacing 31 to 34
- power supply
 - adding 27
 - Disk DCC 35
 - LEDs 8, 25
 - location 24
 - N+1 redundancy 24
 - replacing 26
- power system 24 to 42

R

- removing
 - plastic side covers
 - HDDA chassis 5
 - power shelf chassis 32
 - snap-catch 5
- replacing
 - Disk DCC 36 to 42
 - drive drawer 9 to 17
 - drive drawer fuse 18 to 23
 - HDDA chassis 3 to 8
 - HDDA fan 43 to 44
 - PDU 28 to 30
 - power shelf chassis 31 to 34
 - power supply 26
 - SCSI cables 45 to 46

S

- SCSI cables
 - replacing 45 to 46
- SCSI cabling example 46
- snap-catch 5, 32

U

- unlocking the HDDA drive drawer 11, 36

W

- wrist strap jack 2